

Lock Up Valves
YT-400, YT-405

USER'S MANUAL

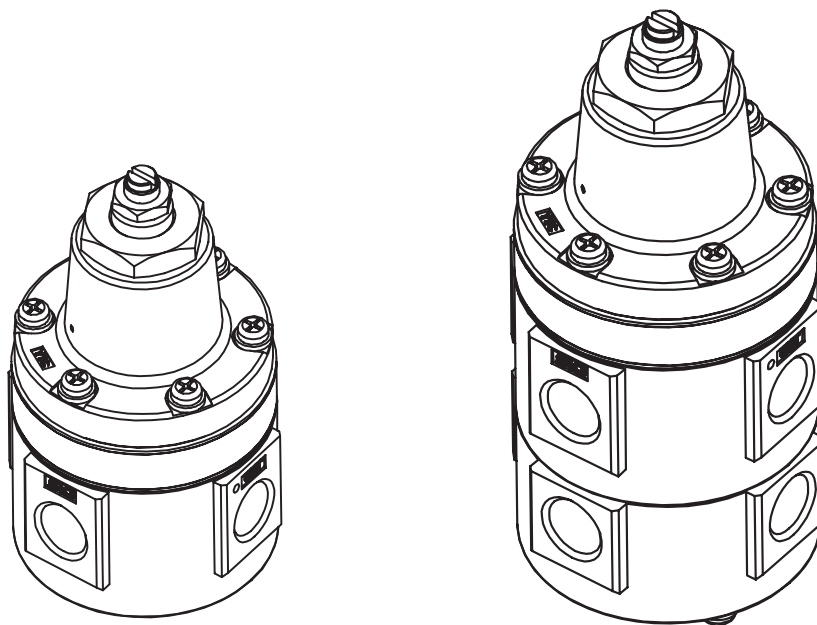

YTC

V.1.01

Product Description

Lock Up Valve, YT-400 (YT-405), senses the main supply pressure and shuts down the air flow when the pressure is lower than setting level to avoid system shutdown or damages to pipelines.

Product Characteristic

- Due to its compact size and light weight, Lock Up Valve can be installed without bracket.
- It responses to less than 0.1kgf/cm² pressure change/s.
- Epoxy powder coating resists against the corrosion.
- 100 mesh screen filters small dust entering.

Label

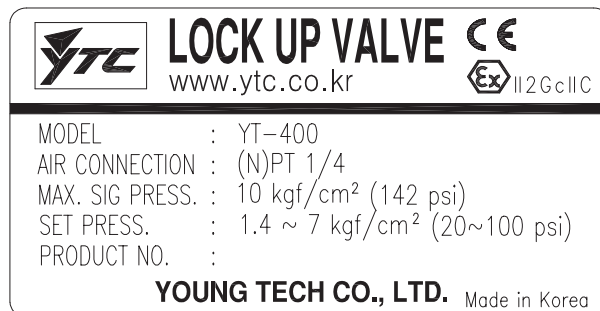

- MODEL:** Indicates product's model, suffix, and options (if any).
- AIR CONNECTION:** Indicates the port size of air connection.
- MAX. SIG. PRESS.:** Indicates maximum level of signal pressure.
- SET PRESS.:** Indicates pressure range.
- PRODUCT NO.:** Indicates serial number.

Suffix Symbol

YT-400(YT-405) follows suffix symbols as below.

YT-400 / YT-405 **①** **②**

① Acting Type	S : Single Acting
	D : Double Acting
② Connection Typ	P : PT 1/4
	N : NPT 1/4 *

* NPT 1/4 Connection type is only available for YT-405 model.

Specification

Category	YT-400S	YT-400D	YT-405S	YT-405D
Max Supply Pressure	Max. 10.2kgf/cm ² (142psi)			
Max Signal Pressure	Max. 7.1kgf/cm ² (100psi)			
Setting Pressure Range	1.4-7.1kgf/cm ² (20~100psi)			
Flow Capacity (Cv)	0.9			
In/Output Port Connection	PT (NPT) 1/4		NPT 1/4	
Signal Port Connection	PT (NPT) 1/4		NPT 1/4	
Differential Pressure	Below 0.1kgf/cm ² (1.4psi)			
Hysteresis	1%			
Ambient Temperature	-20℃~70℃			
Material	Aluminum Diecasting		Stainless Steel 316	
Weight	0.15kg	0.7kg	1.1kg	1.5kg

Parts and Assembly

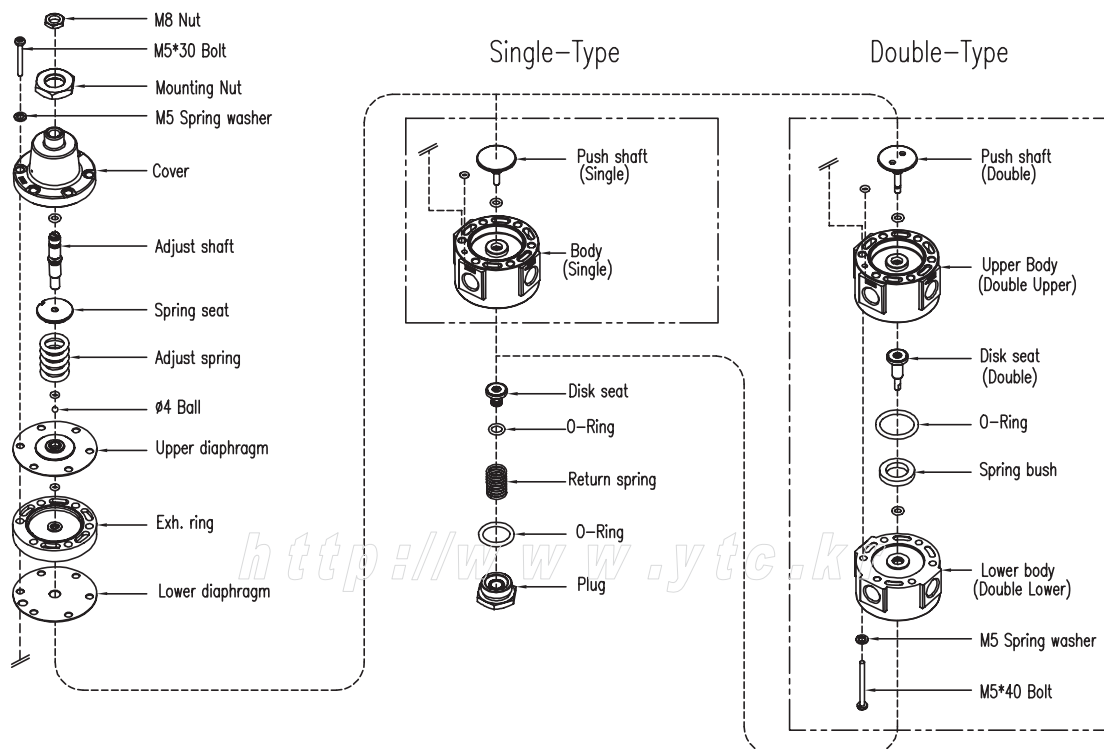

Please be knowledgeable of product's major parts and assembly steps for future maintenance.

Operation Logic

When signal pressure is greater than setting pressure level, upper diaphragm(⑧) is being pushed upward by signal pressure. As it gets pushed upward, vent port through lower diaphragm(⑩) opens, so signal pressure pushes down lower diaphragm(⑩). Lower diaphragm(⑩) pushes push-shaft(⑪) and push-shaft(⑪) pushes disk-seat(⑬), which supply pressure will vent out through Lock Up Valve. Opposingly, when signal pressure is less than setting pressure level, upper diaphragm(⑧) is being pushed downward and lower diaphragm(⑩) will block signal-in port. 4 Ball(⑦) will be detached from upper diaphragm(⑧) and the pressure will be exhausted.

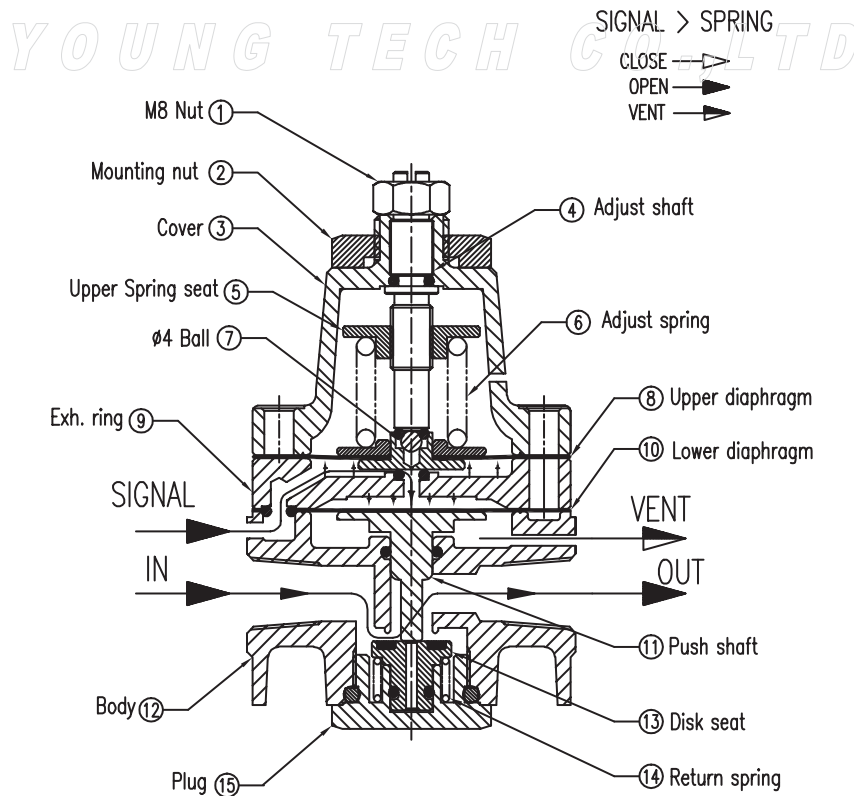

Dimension (outer)

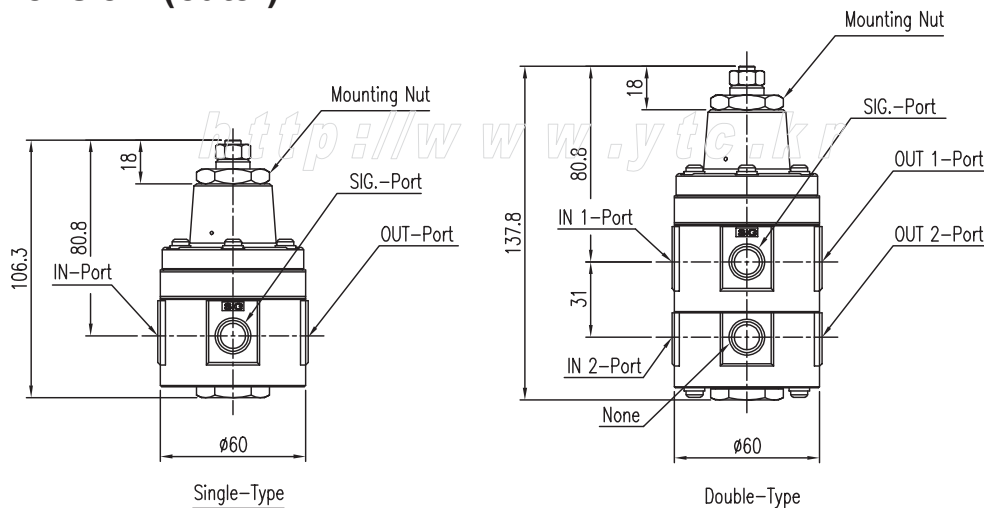

Installing

⚠ Caution

When installing the product, please follow below procedures.

- Always wear safety equipments and follow safety procedures.
- Please operate within the range of specified capacity in the manual. If exceeded, the product can be damaged and may result serious damages and accident.
- Air must be clean, dry, and non-corrosive, which must pass filter.
- Make sure no substances entering into signal pressure port. Any metal or sharp substance may damage diaphragm.
- Make sure to use pressure reading devise when setting pressure level.
- Install in correct order when other devices are being operated. Make sure the Lock Up Valve is connected to the actuator.

Pipe Connection

YT-400 must be installed between actuator and positioner without a bracket <Figure 1>, which can be installed on through the pipeline. Before connecting with pipeline, please make sure pipeline is emptied, and the size of the pipeline is appropriate for required capacity.

If YT-400 must be installed on the bracket, please make a bracket according to the product's dimension. <Figure 2>

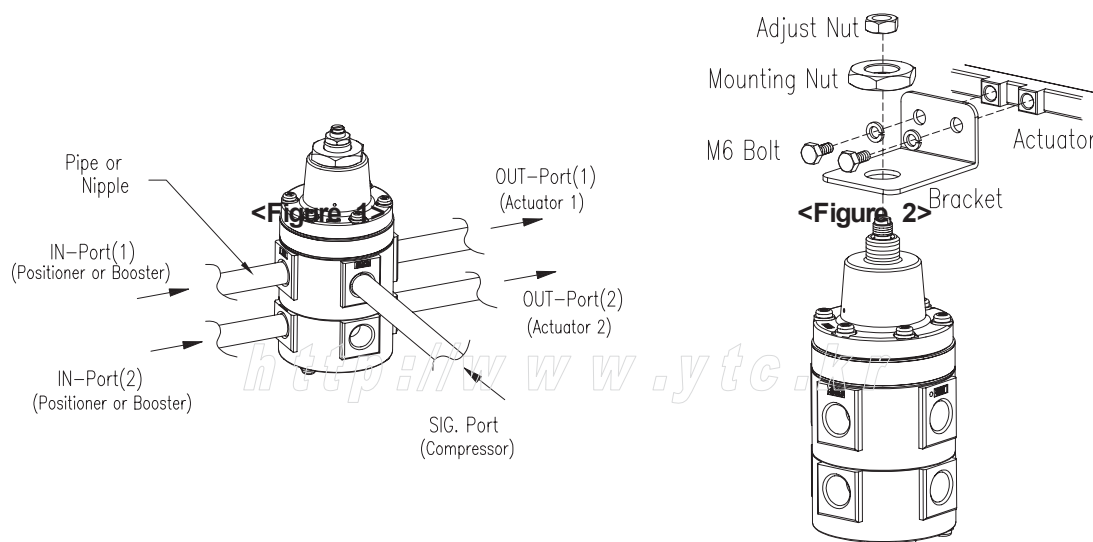

Install Example

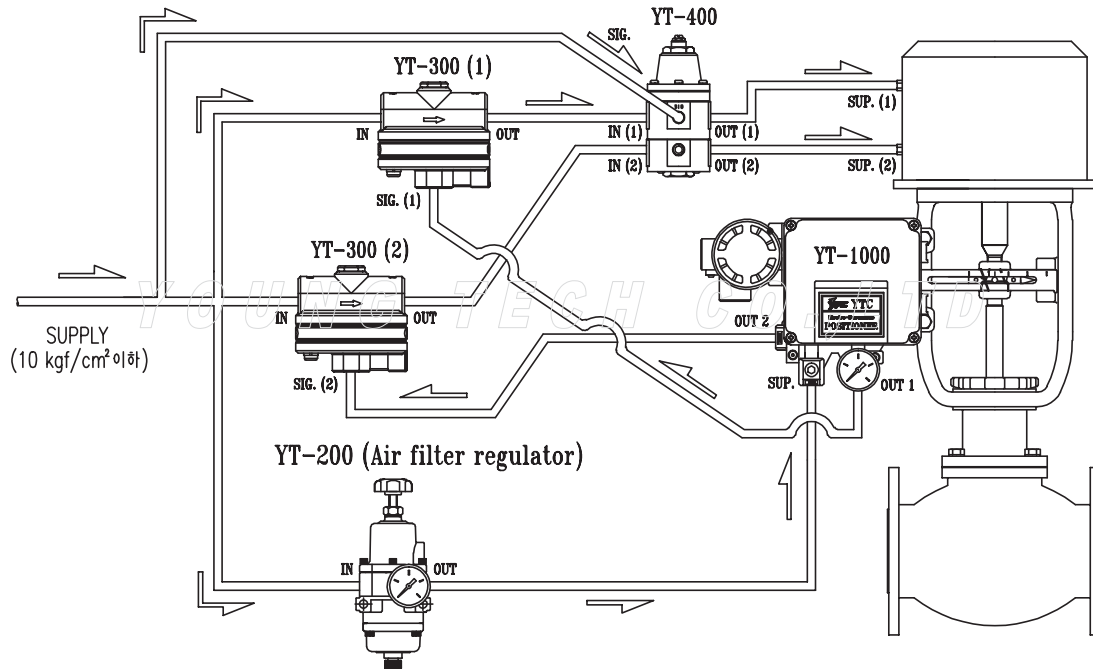

<Linear Actuator Type>

YT-200 (Air filter regulator)

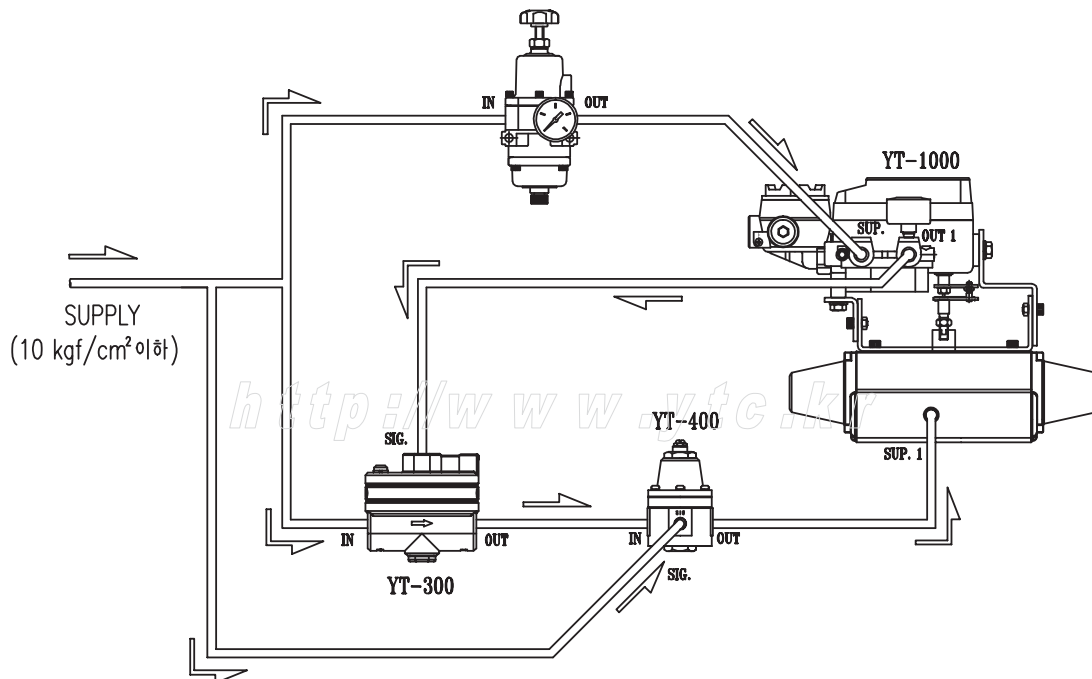

<Rotary Actuator Type>

Maintenance

Please refer to below table (repair kit) and parts' name (pg 2). Before replacing any parts, please make sure to follow field's safety instruction and manual to avoid any accidents and damages to the product.

Repair kit

Part Name	YT-400S, 405S	YT-400D, 405D
Upper Diaphragm Assembly	1 (set)	1 (set)
Lower Diaphragm	1 (ea)	1 (ea)
Disk	1 (ea)	1 (ea)
O-ring	7 (ea)	9 (ea)

When using Repair Kit, all of the parts must be replaced at the same time. Partial replacing part may result shortening product's life cycle.

Troubleshooting

▶ **Lock Up Valve does not block pressure when signal pressure is lower than setting pressure level**

Please check if setting pressure is correctly set. If setting pressure is extremely high, please lower the setting pressure level. Default setting pressure level is 3 kgf/cm² when manufactured.

▶ **Lock Up Valve blocks pressure when signal pressure is higher than setting pressure level.**

Please check if setting pressure is correctly set. If setting pressure is too low, please increase the setting pressure level. Default setting pressure level is 3 kgf/cm² when manufactured.

▶ **Air pressure is exhausted through spring case holes.**

Upper diaphragm may be damaged. If it is damaged, please replace the upper diaphragm. If problem persists, please open the spring case and clean the surface.

▶ **Air pressure is exhausted through Lock Up Valve body holes.**

Either lower diaphragm or O-ring may be damaged. If lower diaphragm is damaged, please replace it. If O-ring is damaged, please contact YTC office.