

VOLUME BOOSTER RELAYS YT-310 / 315 SERIES

PRODUCT MANUAL



MIEPL
INDIAN SALES PARTNER

YTC
YOUNG TECH Co., Ltd

VERSION 1.02

Contents

1. Introduction	3
1.1 General information for the users	3
1.2 Manufacturer Warranty	3
2. Product Description	4
2.1 General	4
2.2 Main Features and Functions	4
2.3 Label Description	4
2.4 Product Number	4
2.5 Product Specification	5
2.6 Parts and Assembly	5
2.7 Operation Logic	6
2.8 Dimension	6
3. Installation	7
3.1 Safety	7
3.2 YT-310/315 Installation	7
3.3 Installation Example	8
4. Maintenance	9
5. Trouble-Shooting	9

1. Introduction

1.1 General Information for the users

Thank you for purchasing Young Tech Co., Ltd products. Each product has been fully inspected after its production to offer you the highest quality and reliable performance. Please read the product manual carefully prior to installing and commission the product.

- For the safety, it is important to follow the instructions in the manual. Young Tech Co., Ltd will not be responsible for any damages caused by user's negligence.
- The manual should be provided to the end-user.
- Any modifications or repairs to the product may only be performed if expressed in this manual.
- The manual can be altered or revised without any prior notice. Any changes in product's specification, design, and/or any components may not be printed immediately but until the following revision of the manual.
- The manual should not be duplicated or reproduced for any purpose without prior approval from Young Tech Co., Ltd, Gimpo-si, South Korea.

1.2 Manufacturer Warranty

- For the safety, it is important to follow the instructions in the manual. Manufacturer will not be responsible for any damages caused by user's negligence.
- Manufacturer will not be responsible for any damages or accidents as a result of any alteration or modification of the product and its parts. If any alteration or modifications are necessary, please contact Young Tech Co., Ltd directly.
- Manufacturer warrants the product from the date of original purchase of the product for one (1) year, except as otherwise stated.
- Manufacturer warranty will not cover products that have been subjected to abuse, accidents, alterations, modifications, tampering, negligence, misuse, faulty installation, lack of reasonable care, repair or service in any way that is not contemplated in the documentation for the product, or if the model or serial number has been altered, tampered with, defaced or removed; damages that occurs in shipment, due to act of God, failure due to power surge, or cosmetic damage. Improper or incorrectly performed maintenance will void this limited warranty.
- For detailed warranty information, please contact Young Tech Co., Ltd – South Korea.

2. Product Description

2.1 General

Volume booster relay, YT-310 / YT-315, is used in pneumatic control valve which receives the output signal from positioned and supply air pressure to actuator to reduce opening and closing time of the valve.

2.2 Main Features and Functions

- Constant air pressure at the ratio of 1:1
- By-pass control enhances safety of the control valve operation.
- Response to slight changes in input signal, which increases accuracy of the output pressure to actuator.
- Internal 100 mesh screen filters small dust entering into the product.
- SIL 3 certified

2.3 Label Description

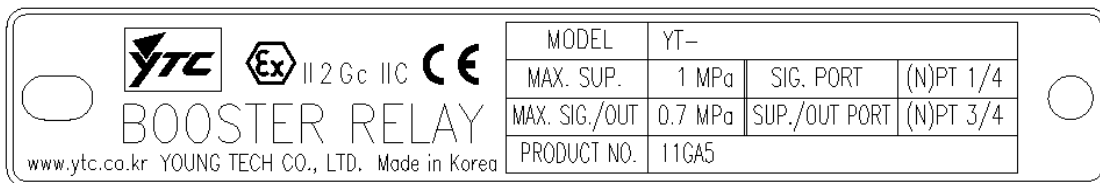

Fig. 1: YT-310/ 315 Body Label

- | | |
|-------------------------|--|
| A. Model: | Indicates the model number |
| B. Max. Sup.: | Indicates maximum supply pressure range. |
| C. Max Sig./Out Press.: | Indicates maximum signal / output level. |
| D. Product No.: | Indicates the lot number. |

2.4 Product Number

YT-310 / 315



1	Connection Type	1	PT
		2	NPT
2	Ambient Temp	1	-20 ~ 70 'C
		2	-20 ~ 120 'C
		3	-40 ~ 70 'C

2.5 Product Specification

Model		YT-310	YT-315
Max Supply Pressure		1 MPa (10 bar)	
Max Sig. / Out Pressure		0.7 MPa (7 bar)	
In / Output Pressure Ratio		1 : 1	
Flow Capacity (Cv)	Output	3.2	
	Exhaust	5.6	
In / Out Connection		PT / NPT 1/2	NPT 1/2
Signal Connection		PT / NPT 1/4	
Linearity		+ / - 1 % F.S.	
Ambient Temperature		Standard Temp. : -20~70°C High Option Temp. : -20~120°C Low Option Temp: -40~70°C	
Material		Aluminum	Stainless Steel 316
Weight		2.3 kg	5.0 kg



Tested under ambient temperature of 20°C, absolute pressure of 760mmHg, and humidity of 65%. Please contact Young Tech Co., Ltd for detailed testing specification.

2.6 Parts and Assembly

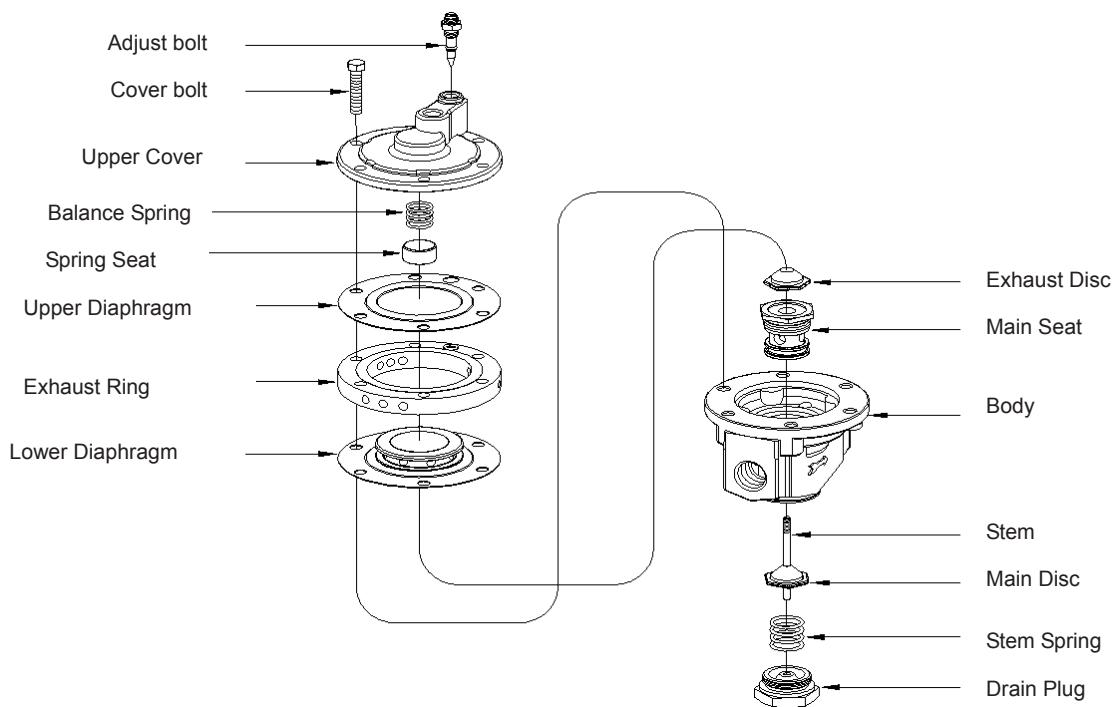

2.7 Operation Logic

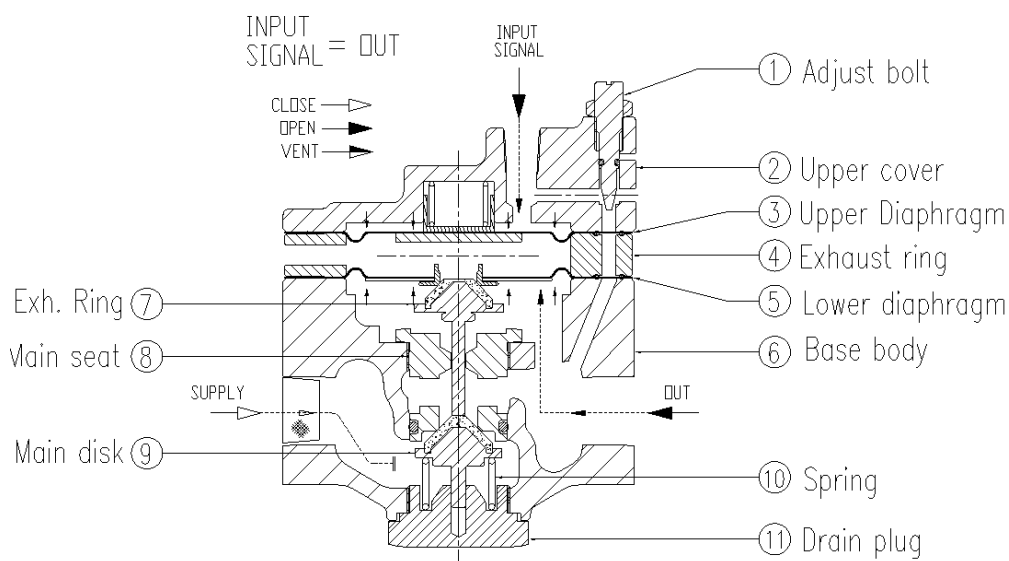

As supply pressure from regulator is connected to supply port and signal pressure is connected to supply port, upper diaphragm (③) and diaphragm assembly will get pushed down. As they are being pushed down, they push stem and supply pressure will be exhausted to output port. As output and supply pressure is equalized, stem will be moved to keep signal and output pressure the ratio of 1:1. If output pressure is higher than signal pressure, diaphragm assembly will be raised, and output pressure in the exhaust ring (⑦) will be exhausted through exhaust port. The sensitivity of output pressure to signal pressure can be adjusted by setting adjust bolt (①).

2.8 Dimension

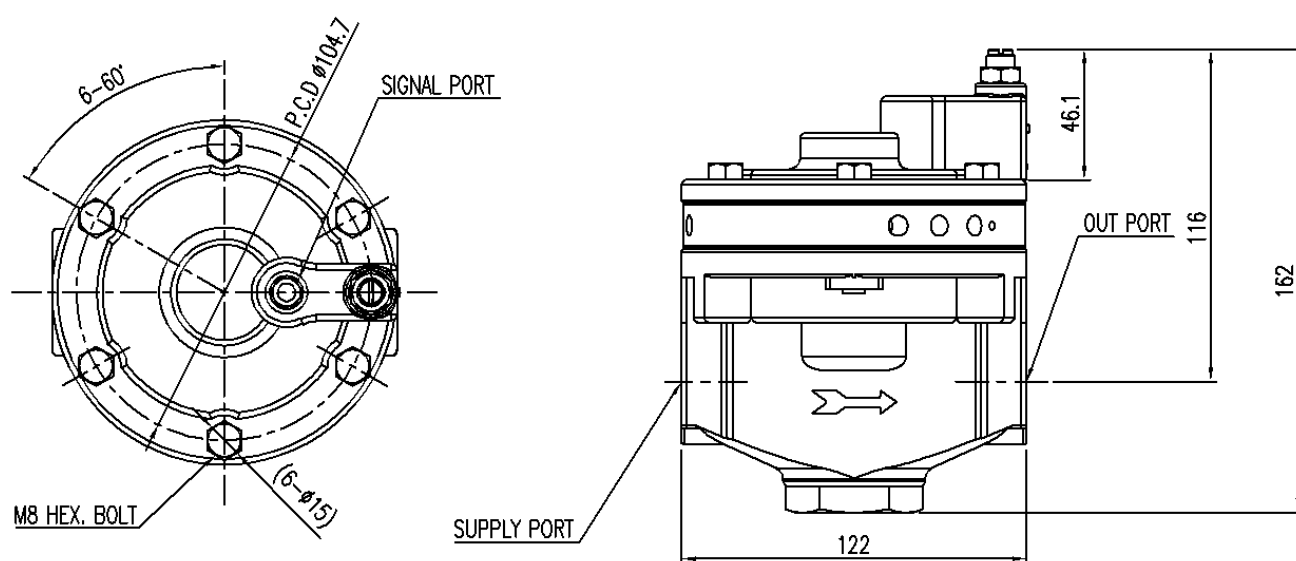

3. Installation

3.1 Safety

When installing a unit, please ensure to read and follow safety instructions.



- Check unit's specification and ensure to use as specified.
- Use bypass valve or other supportive equipment to avoid entire system "shut down".
- Ensure to use filter regulator.
- Use manometer to monitor the pressure level when setting the pressure level.

3.2 YT-310 / 315 Installation

YT-310 / 315 can be installed with or without a bracket depending on the field requirement.

Please refer to YT-310 / 315 dimension to build appropriate bracket, if required.

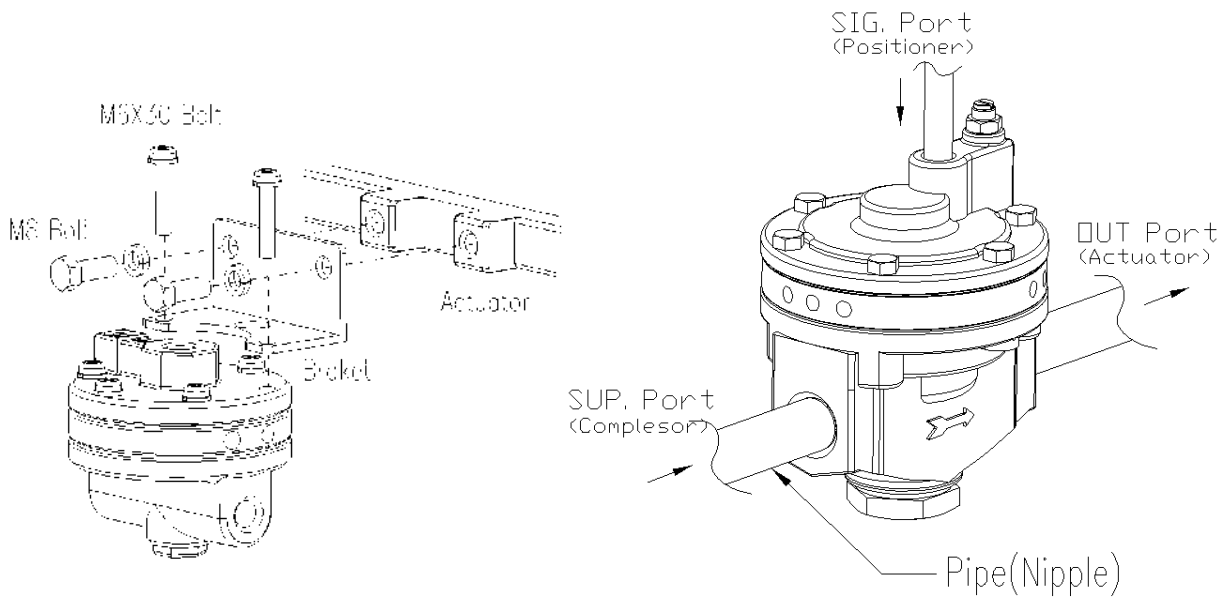

3.3 Installation Example

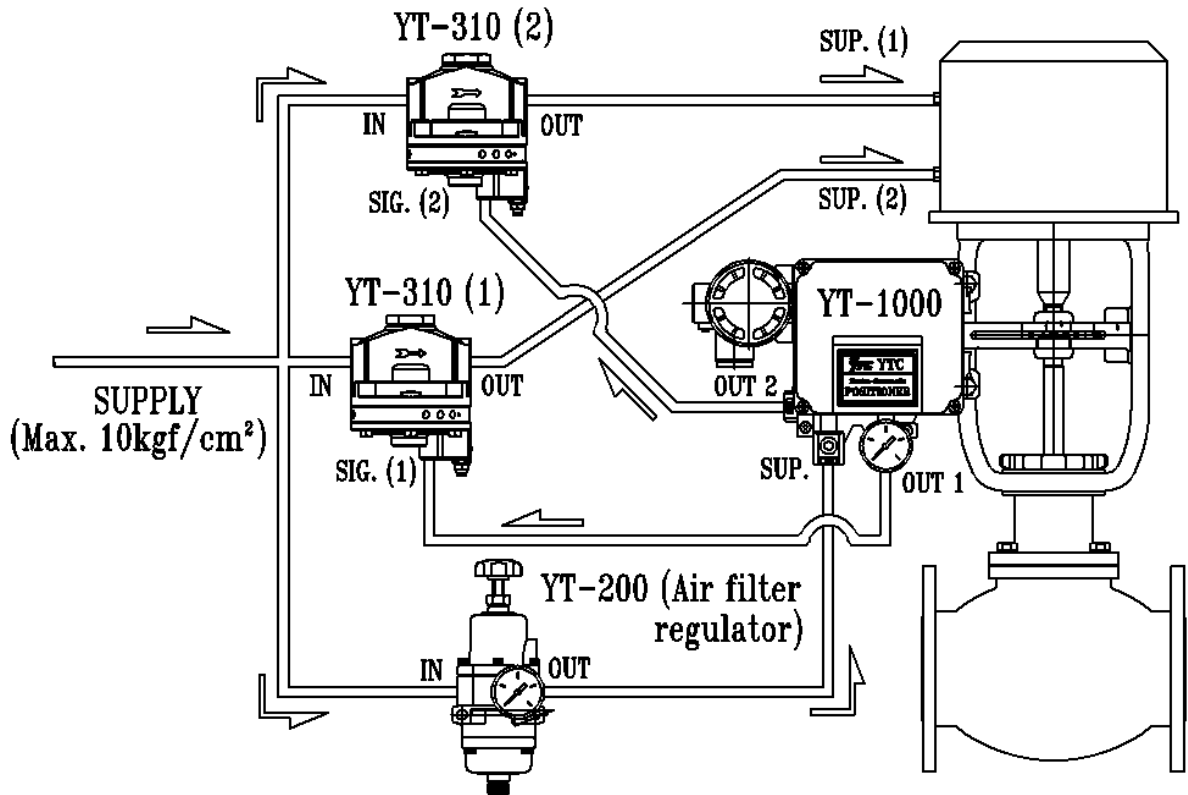

Double acting linear actuator

YT-200 (Air filter regulator)

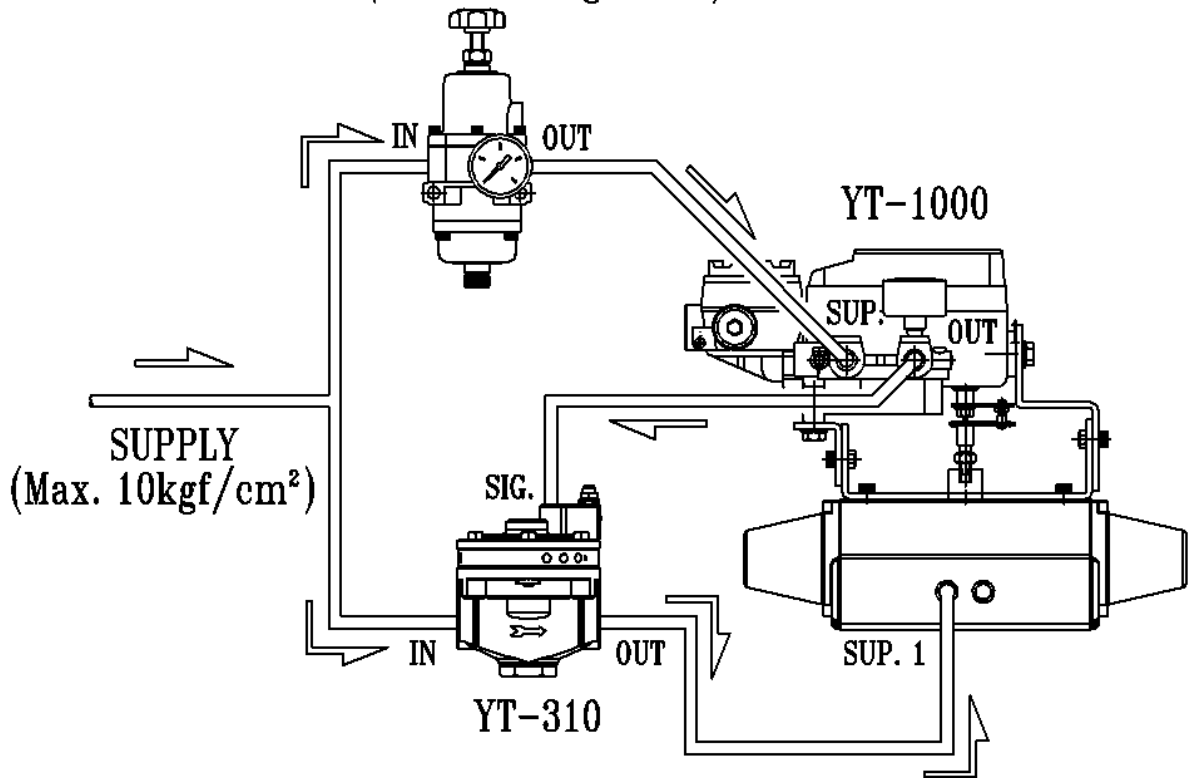

Single acting rotary actuator

4. Maintenance

4.1 YT-520/525 requires regular maintenance. Please refer to below repair kit part list. It is suggested to replace all three parts at the same time to guarantee the life cycle of the product.

- Upper diaphragm assembly: 1 each
- Lower diaphragm: 1 each
- O-rings: 2 each

5. Trouble-Shooting

Please follow trouble-shooting when the product is not functioning properly.

- No valve response to signal to a positioner.
 - Please check if supply pressure is stable from regulator to positioner and/or to volume booster.
 - Please check if air pressure is being exhausted from positioner's exhaust port.
 - Please check if signal and exhaust ports of the volume booster are being cleared.
- Unstable valve operation when signal has been sent to a positioner.
 - Please reduce valve packing and/or valve friction level.
 - Please check current actuator size and check if volume booster size is suitable.
- Hunting occurs when signal has been sent to a positioner.
 - Please reduce valve packing and/or valve friction level.
 - Please check current actuator size and check if volume booster size is suitable.
 - Please turn adjust screw counter-clockwise to reduce sensitivity.
- Slow valve operation after installing a volume booster.
 - Please check if regulator pressure is too low.
 - Please check if supply piping to the actuator has been blocked or clogged.
 - Please check if there is any leakage.
 - Please turn adjust screw clockwise to enhance sensitivity.