

USER'S MANUAL

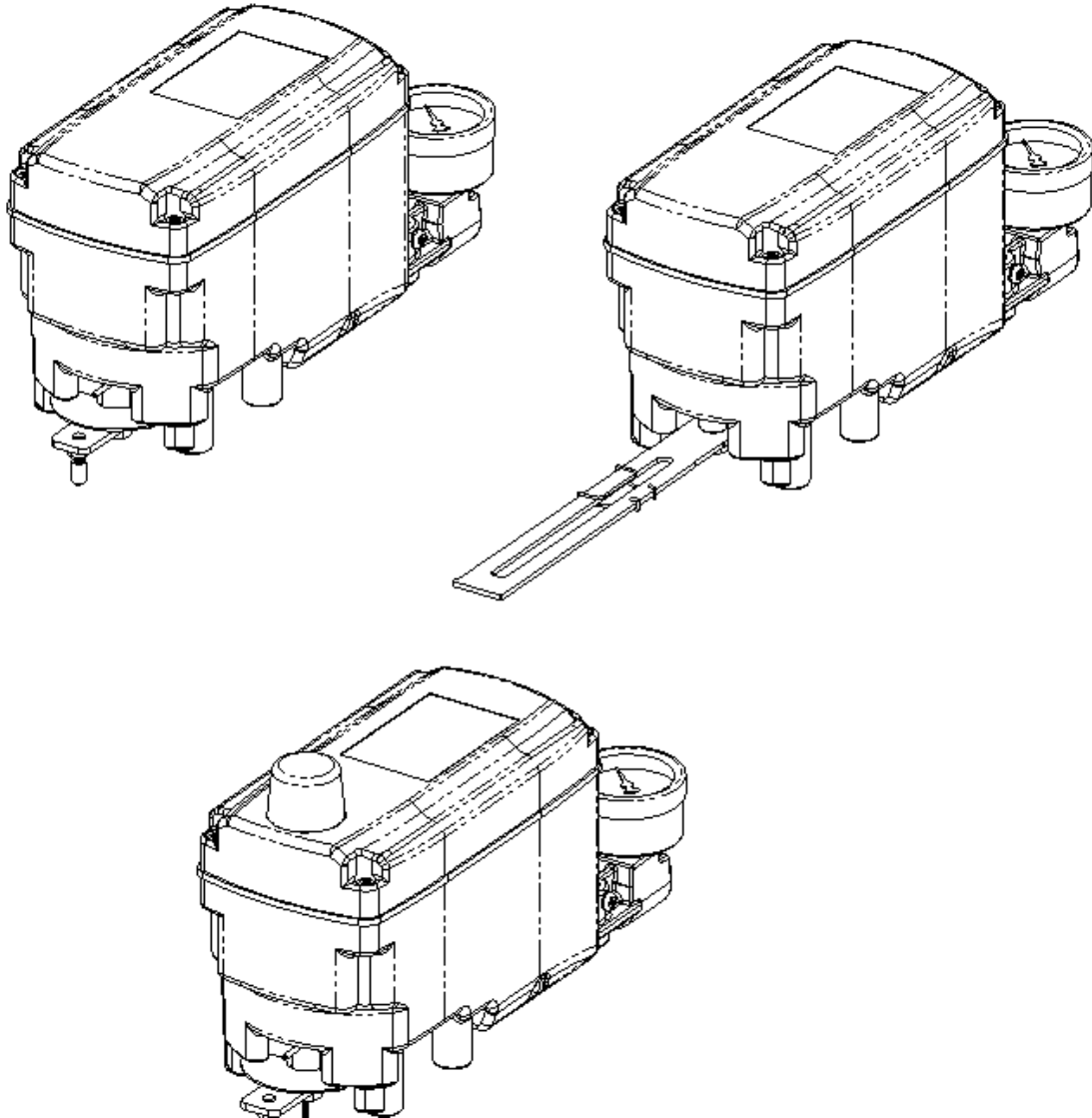

Table of Contents	
Introduction	4
Manufacturer Warranty	4
Product Description	5
Main Features and Functions	5
Label Description	6
Suffix Symbol	7
Specification – YT-2500	8
Specification – YT-2550	9
Parts and Assembly	10
Dimensions – YT-2500	11
Dimensions – YT-2550	12
Installation	14
YT-2500/2550L Installation	14
YT-2500R/2550R Installation	17
Connection	22
Connection - Piping	22
Piping Connection with Actuator	22
Connection - Power	23
Connection - Feedback Signal	25
Connection - Ground	25
Adjustment	25
Variable Orifice	25
Option Modules PCB	26
Limit Switch Adjustment	27
Auto Calibration and Basic Operation	28
Button Description	28
Run Mode (RUN)	28
Auto Calibration (AUTO CAL)	29
Auto 1 Calibration	29
Auto 2 Calibration	30
Auto HF Calibration	30
Manual Mode (Manual)	31

Parameter Mode (PARAM)	31
Dead-Zone (dEAdZONE)	32
P-Value (KP1)	32
P2-Value (KP2)	33
D1-Value (Kd1)	33
D2-Value (Kd2)	33
PT-Value (PT1)	33
PT-Value (PT2)	33
KP and D Value	33
Hand Calibration Mode (HAND CAL)	34
Zero-Point (PZ_ZERO) and End-Point (PZ_END) for Valves	34
Zero-Point (TR_ZERO) and End-Point (TR_ZERO) for Transmitter	34
End-Point Ratio for Valve (PE_TRIM)	35
Normal/Reverse Feedback Signal (TR_NORM/REV)	35
Valve Mode (VALVE)	36
Acting Adjustment (ACT)	36
Characteristic Adjustment (CHAR)	36
User Characteristics (USER SET)	37
Tight Shut Open (TSHUT OP)	37
Tight Shut Close (TSHUT CL)	37
Split Range Control (SPLIT)	38
View Mode (VIEW)	38
Error and Warning Code	39
Main Software Map	40

Introduction

Thank you for choosing YTC product. Each product is fully inspected after the production to offer you the highest quality. In order to fully utilize the product, we strongly recommend users to read the manual carefully and fully understood.

- The manual should be provided to the end-user.
- The manual can be altered or revised without any prior notice. Any changes in product's specification, structure, and/or any components may not result immediate revised version of the manual.
- The manual should not be duplicated or reproduced for any purpose without any approval from Young Tech Co., Ltd, South Korea.

Manufacturer Warranty

- For the safety, it is imperative to follow instructions in the manual. It is not manufacturer's liability for any damages which caused by users' negligence.
- It is not manufacturer's liability for any damages or accidents which resulted by any alteration or modification of the product and parts. If alteration or modification is necessary, please contact the manufacturer directly.
- Manufacturer warrants the product from the date of original retail purchase of the product for one (1) year, except as otherwise stated.
- Manufacturer warranty will not cover the products that the product have been subjected to abuse, accident, alteration, modification, tampering, negligence, misuse, faulty installation, lack of reasonable care, repair or service in any way that is not contemplated in the documentation for the product, or if the model or serial number has been altered, tampered with, defaced or removed; damages that occurs in shipment, due to act of God, failure due to power surge, and cosmetic damage. Improper or incorrectly performed maintenance or report voids this Limited Warranty.
- For detailed warranty information, please contact the corresponding local Young Tech Co., Ltd office or main office in South Korea.

Product Description

YT-2500/2550 Smart Valve Positioner accurately controls valve stroke, according to input signal of 4-20mA, which is being input from the controller. In addition, built-in micro-processing operator optimizes the positioner's performance and provides unique functions such as Auto calibration, PID control, Alarm, and Hart protocol.

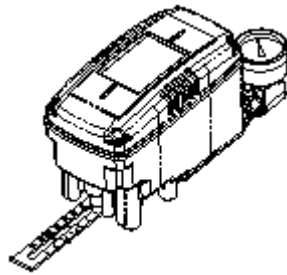

YT-2500/2550L

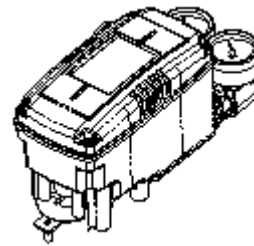



YT-2500/2550R

Main Features and Functions

1. YT-2500/2550 series freezes at the last position when the input signal and/or supply pressure fails without any additional accessories, such as lock-up valve or solenoid valve.
2. LCD display enables users to monitor the status of the positioner.
3. The positioner operates normally even if there are sudden changes in supply pressure and in high vibration environment.
4. The method of Auto Calibration is very simple.
5. Due to the small size of the positioner, it can be installed on a small actuator.
6. Low air consumption level and low voltage use (8.5V) yield to lower operating cost. The positioner is compatible with most of controllers.
7. Variable orifice can minimize the hunting occurrence and optimize operating condition.
8. Various sets of information can be interchanged by HART communication protocol between a valve and a positioner.
9. Valve system becomes more stable by outputting analog feedback signal.
10. Various characteristics of valve can be adjusted – Linear, Quick open, and Equal percentage.
11. Tight Shut – Close and Shut-Open can be set.
12. PID parameters can be adjusted in the field without any additional communicator.
13. A/M switch can change the flow of the pressure, whether to send directly to actuator or to operate by positioner.
14. Split range 4-12mA or 12-20mA can be set.
15. Hand calibration function can be set Zero and Span values.
16. It has IP66 protection grade.
17. Air filter regulator can be attached with only one linear nipple. It does not require extra piping.
18. Epoxy polyester powder coating resists against the corrosion process.
19. Maintenance of the positioner is easy because of modularized inner structure.



Label Description

MODEL NUMBER	YT-2500	
EXPLOSION PROOF	Ex ia IIC T5/T6, IP66	
INPUT SIGNAL	4~20mA DC	10-00000-0000
OPERATING TEMP.	-30°C ~ 85°C (-22°F ~ 185°F)	
EXPLOSION TEMP.	-40°C ~ 60°C (T5) / -40°C ~ 40°C (T6)	
SUPPLY PRESSURE	1.4~7 kgf/cm ²	
Ui, li, Pi, Ci, Li,	See Certificate	
SERIAL NUMBER		

 SMART POSITIONER www.ytc.co.kr
Made in korea

YT-2500 Label

MODEL NUMBER	YT-2550	
EXPLOSION PROOF	Ex ia IIC T5/T6	TPS XX ATEX X XXX X IECEX TUVSPS XX.XXXXX
INPUT SIGNAL	4~20mA DC	
AMBIENT TEMP.	-40°C ~ 60°C (T5) / -40°C ~ 40°C (T6)	
SUPPLY PRESSURE	1.4~7 kgf/cm ²	
Ui, li, Pi, Ci, Li,	See Certificate	
SERIAL NUMBER		

 0123  II 2 G 662-8, Pungmu-dong, Kimpo-City, Kyeonggi-Do, korea

 SMART POSITIONER www.ytc.co.kr
Made in korea

YT-2550 Label

- Model Number: Indicates model name and any option (if any).
- Explosion Proof: Indicates the protection grade.
- Input Signal: Indicates current input signal range.
- Ambient Temperature: Indicates ambient temperature for normal operation.
- Supply Pressure: Indicates the range of supply pressure.
- Ui, li, Pi, Ci, Li: See certificates for parameter values of intrinsically safe.
- Serial Number: Indicates unique serial number.

Suffix Symbol

YT-2500/2550 series follows suffix symbols as follows.

YT-2500/2550 1 2 3 4 5 6 7 8

1 Motion Type	L : Linear R : Rotary
2 Acting Type	S : Single Acting D : Double Acting
3 Explosion Proof	n : non-explosion i : <u>ExialICT6/T5</u>
4 Feedback Lever (YT-2500/2550L)	1 : 10 ~ 40 mm 2 : 20 ~ 70 mm 3 : 50 ~ 100 mm 4 : 100 ~ 150 mm
4 Feedback Lever (YT-2500/2550R)	1 : M6 X 40L 2 : M6 X 63L 3 : M8 X 40L 4 : M8 X 63L 5 : <u>NAMUR</u> Standard
5 Connection Type	1 : PT 1/4 2 : NPT 1/4 *
6 Communication	0 : None 2 : HART Communication
7 Option 1	0 : None 1 : <u>PTM</u> 2 : L/S < <u>Mecahnical</u> > 3 : L/S <Proximity> 4 : <u>PTM</u> & L/S <Mechanical> 5 : <u>PTM</u> & L/S <Proximity>
8 Option 2	F : Fail Freeze S : Fail Safe

** NPT1/4 is only available for YT-2550 series.

Specification- YT-2500

Model	YT-2500L		YT-2500R	
	Single	Double	Single	Double
Acting Type				
Input Signal	4~20mA DC			
Minimum Current Signal	3.2mA(Standard), 3.8mA(Hart Included)			
Supply Pressure	1.4~7kgf/cm ² (0.14~0.7 MPa)			
Stroke	10~150 mm		0~90°	
Impedance	Max.460 Ohm/ 20mA DC			
Air Connection	PT 1/4, NPT 1/4, G 1/4			
Gauge Connection	PT 1/8, NPT 1/8			
Conduit Entry	PF 1/2(Standard), NPT1/2(Option)			
Protection	IP66			
Explosion Proof	ExiaIICT5/T6 *			
Ambient Temperature	Operating Temp: -30~85°C Explosion proof Temp*: -40~60°C(T5)/-40~40°C(T6)			
Linearity	±0.5% F.S.			
Hysteresis	0.5% F.S.			
Sensitivity	±0.2% F.S.			
Repeatability	0.3% F.S.			
Flow Capacity	70 LPM			
Air Consumption	0 LPM (sup=1.4K, idle status)			
Output Characteristic	Linear, Quick Open, EQ%, User Set (16 Point)			
Vibration	No Resonance upto 100Hz at 6G			
Humidity	5-95% RH at 40°C			
Communication (Option)	HART Communication			
Feedback Signal (Option)	4-20mA (DC 10 - 30V)			
Material	Aluminum Diecasting			
Weight	1.5 kg (3.3 lb)			
Painting	Epoxy Polyestere Powder Coating			

* Tested under ambient temperature of 20°C, absolute pressure of 760mmHg, and humidity of 65%. Please contact YTC for the more detailed specification.

* Explosion Proof certification is in progress. Please contact YTC for most current progress.

Specification- YT-2550

Model	YT-2550L		YT-2550R	
	Single	Double	Single	Double
Acting Type				
Input Signal	4~20mA DC			
Minimum Current Signal	3.2mA(Standard), 3.8mA(Hart Included)			
Supply Pressure	1.4~7kgf/cm ² (0.14~0.7 MPa)			
Stroke	10~150 mm		0~90°	
Impedance	Max.460 Ohm/ 20mA DC			
Air Connection	NPT 1/4			
Gauge Connection	NPT 1/8			
Conduit Entry	PF 1/2(Standard), NPT1/2(Option)			
Protection	IP66			
Explosion Proof	ExiaIICT5/T6 *			
Ambient Temperature	Operating Temp: -30~85°C Explosion proof Temp*: -40~60°C(T5)/-40~40°C(T6)			
Linearity	±0.5% F.S.			
Hysteresis	0.5% F.S.			
Sensitivity	±0.2% F.S			
Repeatability	0.3% F.S.			
Flow Capacity	70 LPM			
Air Consumption	0 LPM (sup=1.4K, idle status)			
Output Characteristic	Linear, Quick Open, EQ%, User Set (16 Point)			
Vibration	No Resonance upto 100Hz at 6G			
Humidity	5-95% RH at 40°C			
Communication (Option)	HART Communication			
Feedback Signal (Option)	4-20mA (DC 10 - 30V)			
Material	Stainless Steel 316			
Weight	2.9 kg (6.4 lb)			

* Tested under ambient temperature of 20°C, absolute pressure of 760mmHg, and humidity of 65%. Please contact YTC for the more detailed specification.

* Explosion Proof certification is in progress. Please contact YTC for most current progress.

Parts and Assembly

The structure of YT-2500/2550L is as shown. The only difference between YT-2500/2550L and YT-2500/2550R is the feedback lever.

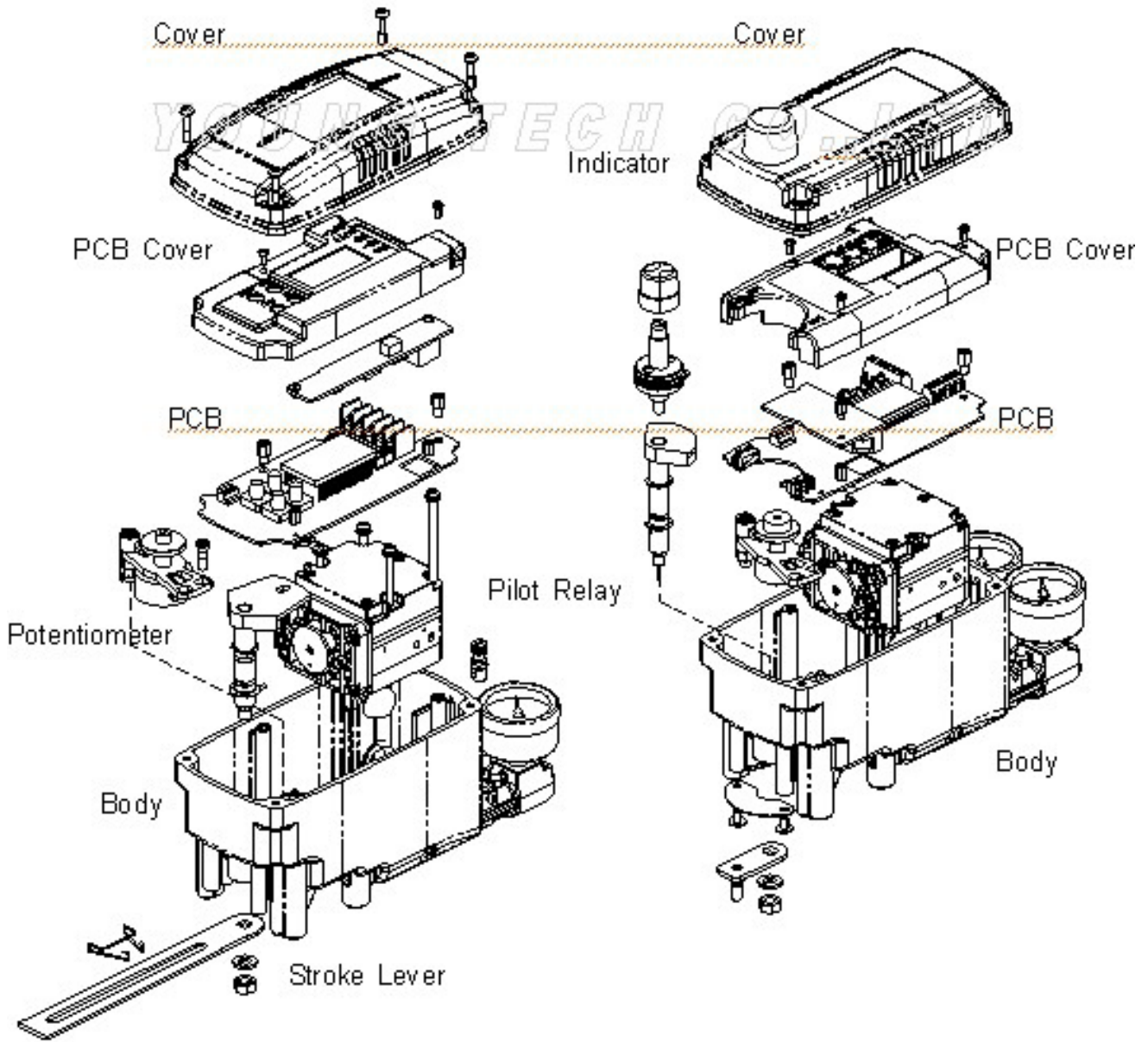

YT-2500/2550L

YT-2500/2550R + L/S option

Dimensions- YT-2500 series

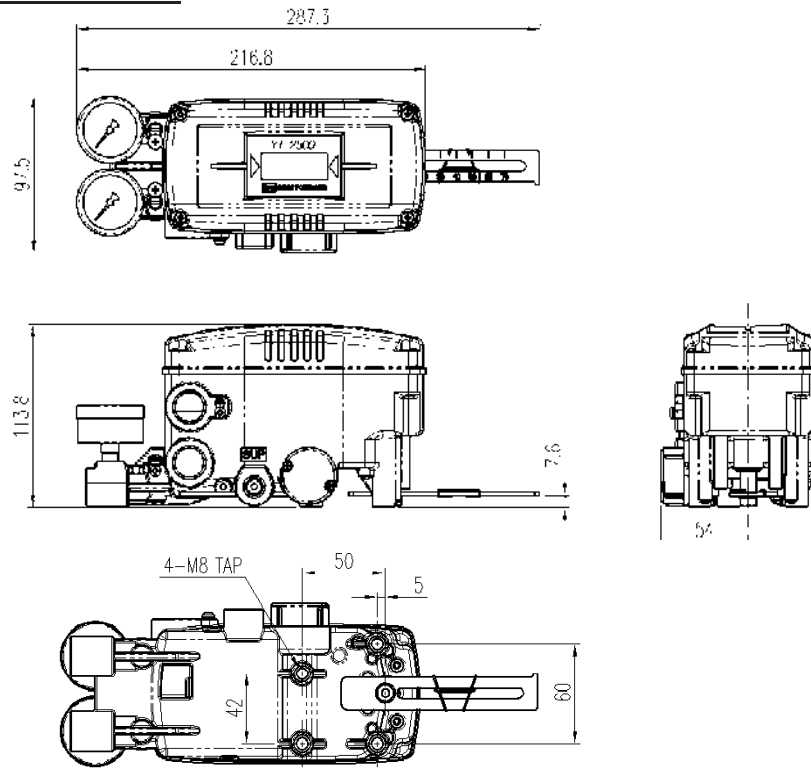

<YT-2500L>

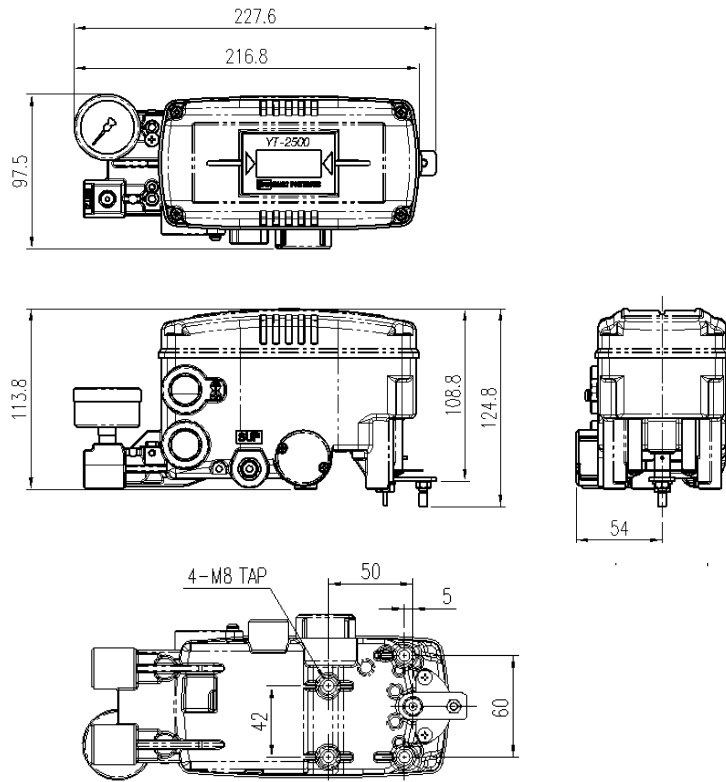

<YT-2500R>

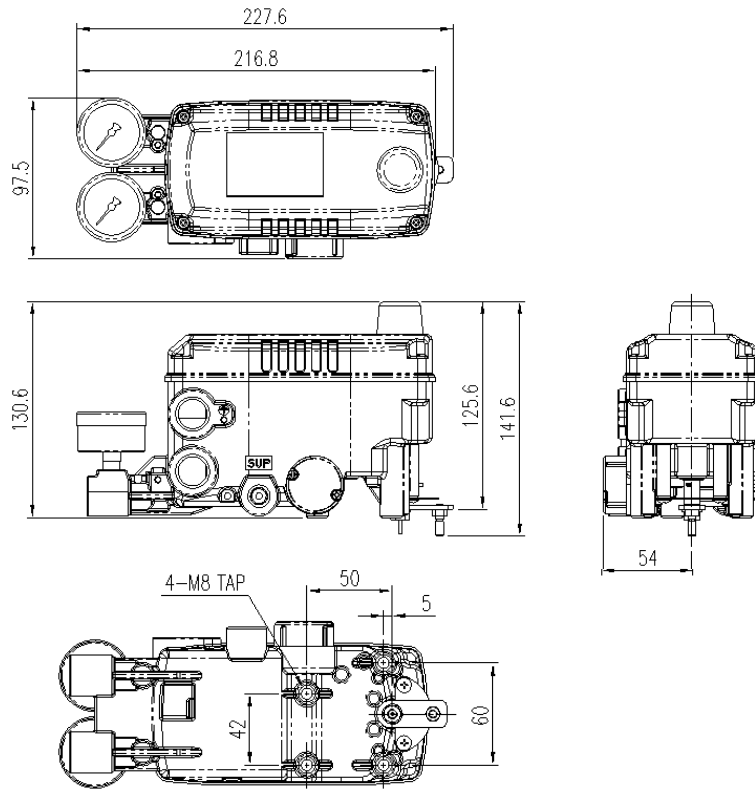

<YT-2500R + L/S option>

Dimensions- YT-2550 series

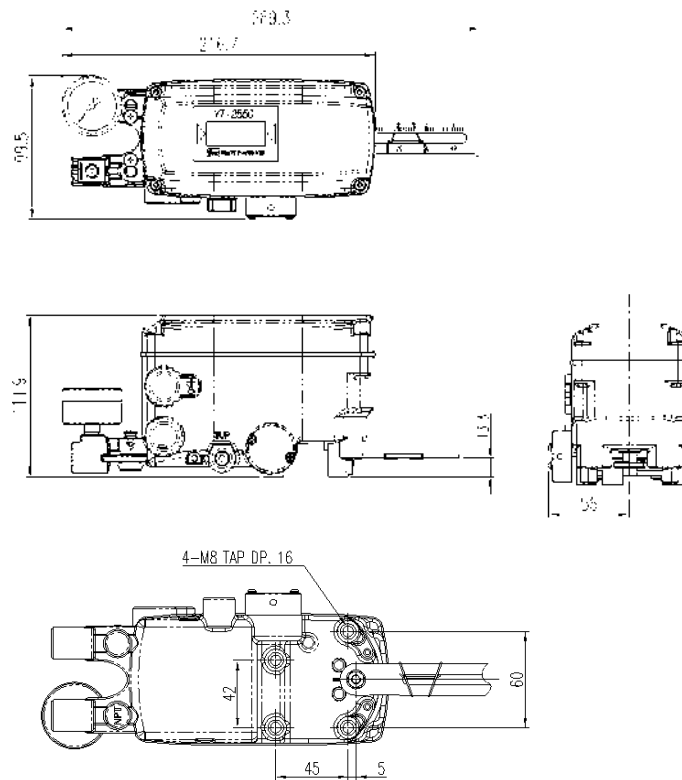

<YT-2550L>

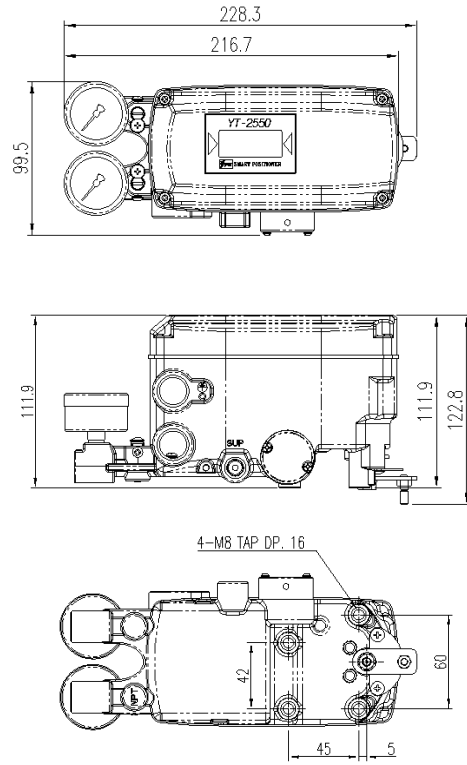

<YT-2550R>

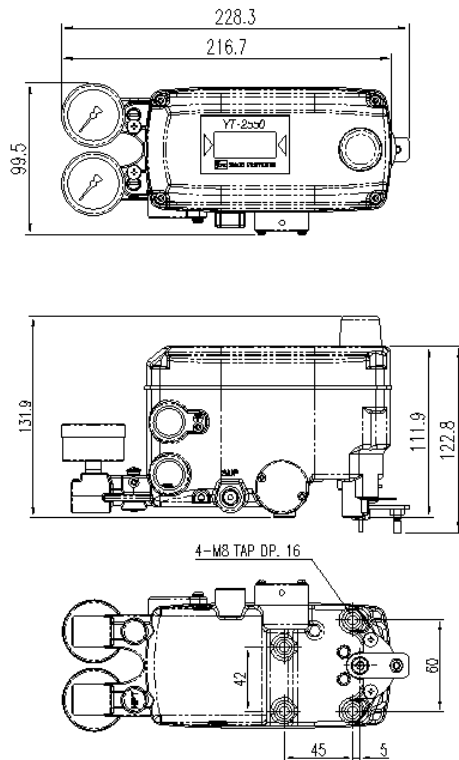

<YT-2550R + L/S option>

Installation

Safety Warning

When installing a positioner, please ensure to read and follow safety instruction.

- All input and supply pressure to valve, actuator, and other related devices must be turned off.
- Use bypass valve or other equipment to avoid entire system "shut down."
- Make sure there is no remaining pressure in the actuator.

Tools for Installation

- ① Hexagonal wrench
- ② Screw drivers (+) & (-)
- ③ Spanners for hexagonal-head bolts

Information for the intrinsically safety

In order to have intrinsically safety functions, barriers must be installed in SAFE area as below.

Required spec of barrier is mentioned below.

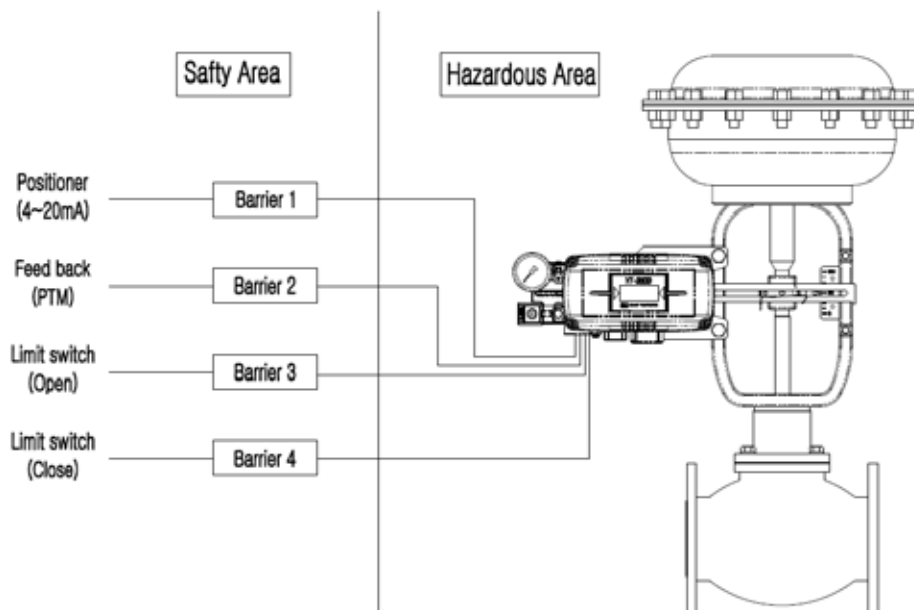

Barrier 1

$U_i=28V$, $I_i = 47mA$, $P_i =329mW$, $C_i = 0.6nF$ differentially between the lines or $2.2nF$ against ground, $L_i = 300 \mu H$, The supply circuit is galvanically isolated against earth.

Barrier 2

$U_i=28V$, $I_i = 47mA$, $P_i =329mW$, $C_i = 0.6nF$ differentially between the lines or $2.2nF$ against ground, $L_i = 300 \mu H$, The PTM circuit is galvanically isolated against earth.

Barrier 3,4

$U_i=28V$, $I_i = 93mA$, $P_i =582mW$, $C_i = 0$, $L_i = 0 \mu H$, The limit switch circuits are galvanically isolated against earth. All circuit are galvanically isolated against each other.

For the purpose of the safety information in this manual and on the product labels, qualified personnel are those who are trained, instructed or authorized to perform work on electrical circuits of equipment subject to explosion hazard.

The instrument must only be installed and commissioned by qualified personnel. The device may be used solely for the purposes described in this manual.

If the intrinsically safe version is operated with a higher operating voltage by mistake, the instrument must no longer be used for intrinsically safe application.

YT-2500/2550L Installation

YT-2500/2550L should be installed on linear motion valve such as globe valve or gate valve using spring return type of diaphragm or piston actuator. Before installation, be sure to check for following installation components.

- ① YT-2500/2550 main body
- ② Feedback lever and lever spring
- ③ Flange nut (bottom side of YT-2500/2550L)
- ④ 4 pcs of hexagon head bolts (M8 x 1.25P)
- ⑤ 4 pcs of M8 plate washer

Installation Steps

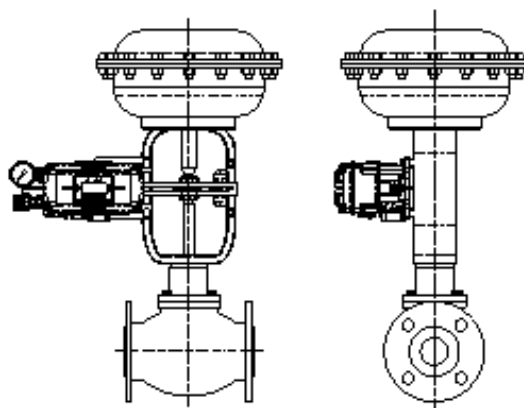

YT-2500/2550L installation example

1) Proper bracket must be made in order to attach positioner on the actuator yoke. Please consider following when making a bracket.

- ① Feedback lever should be leveled at 50% of the valve stroke. (Refer to Step 7)
- ② Feedback lever connection bar of actuator clamp should be installed at the positioner that the valve stroke and numbers which indicated on the feedback lever must be fitted. (Refer to Step 8)

2) Attach YT-2500/2550L to the bracket, which was made in earlier step, by using bolts. <Figure 2> Please refer to backside of the product for size of the bolts. The standard size of bolt is M8 x 1.25P, and other bolt sizes are available. Please contact YTC sales department.

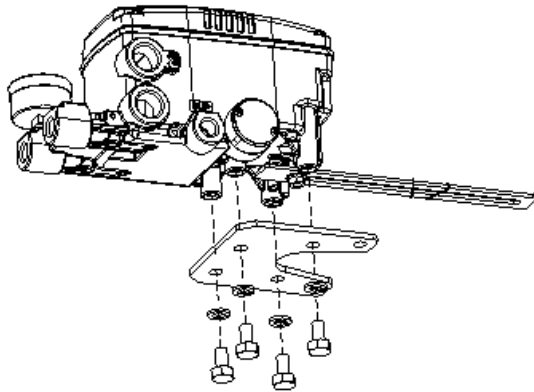

<Figure 2: Installing YT-2500/2550L with bracket>

- 3) Attach YT-2500/2550L (with bracket) to the actuator yoke – DO NOT TIGHTEN COMPLETELY.
- 4) Connect YT-2500/2550L feedback lever to the actuator clamp. The gap on the YT-2500/2550L feedback lever is 6.5mm. The connection bar thickness should be less than 6.3mm. <Figure 3>

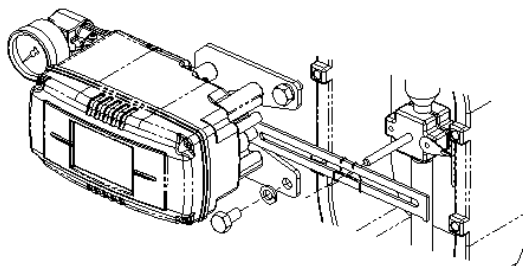

<Figure 3>

- 5) Connect air filter regulator to the actuator temporarily. Set supply pressure of the regulator in order to position the actuator clamp at 50% of valve stroke. <Figure 4>

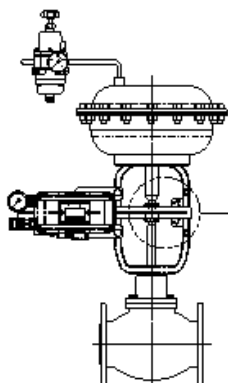

<Figure 4>

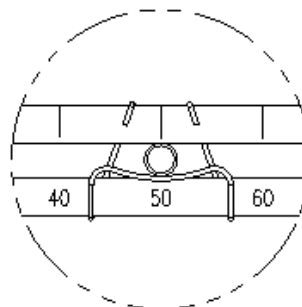

<Figure 5>

- 6) Insert connection bar into the YT-2500/2550L feedback lever. The connection bar should be inserted at the 50% point on the feedback lever, which would help to reduce hysteresis. <Figure 5>
- 7) If connection bar does not point at 50% point, then adjust bracket or feedback link bar position. Failure to position at 50% would lower the linearity of the positioner. <figure 6>

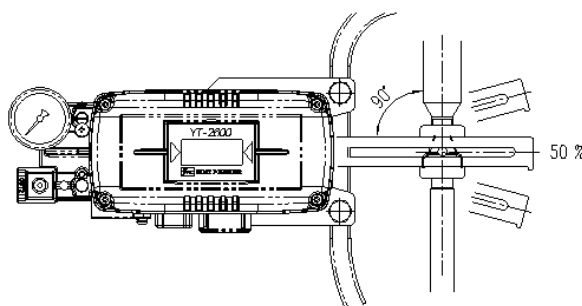

<Figure 6>

- 8) Check valve stroke. The stroke numbers are indicated on the feedback lever. Position connection bar at the number on the feedback lever according to the valve stroke. <Figure 7> To adjust, move the bracket or the connection bar.

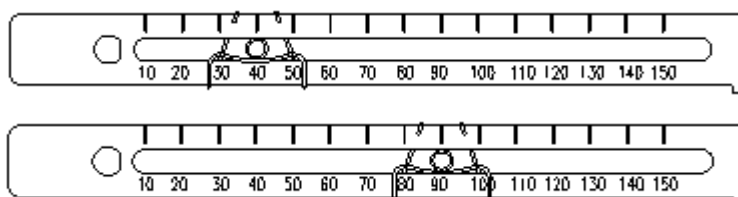

Stroke 40mm

Stroke 90mm

<Figure 7>

Note

After installing YT-2500/2550L, operate the valve from 0% to 100% stroke by using air filter regulator on the actuator. Both of 0% and 100%, the feedback lever should not touch the lever stopper, which is located on the backside of YT-2500/2550L. <Figure 8> If the feedback lever touches the lever stopper, YT-2500/2550L should be installed further away from the center of the yoke.

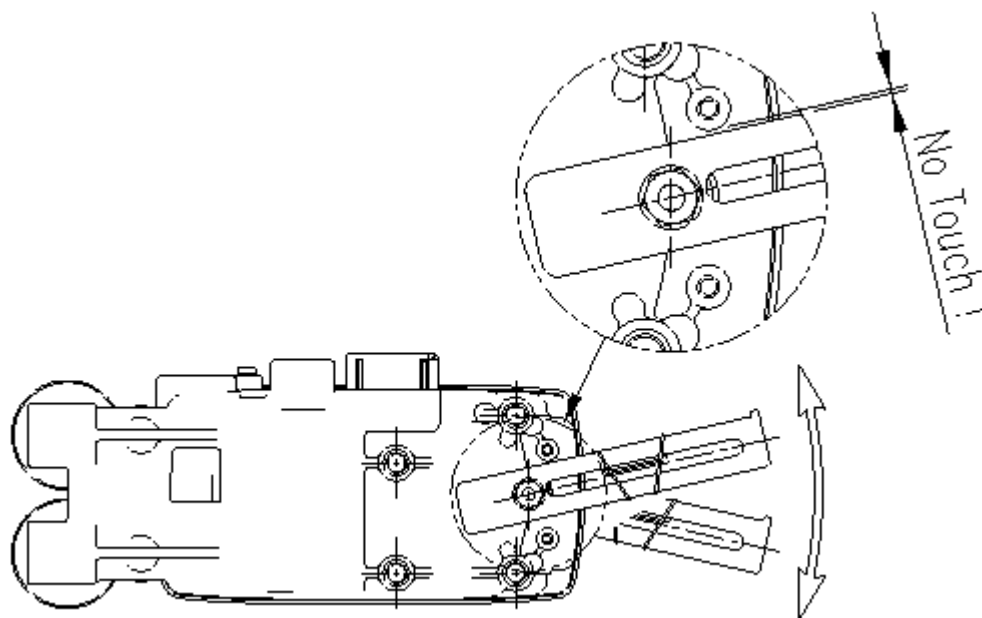

<Figure 8>

- 9) After the proper installation, tighten all of the bolts on the bracket, the feedback lever, and the connection bar.

YT-2500/2550R Installation

YT-2500/2550R should be used for rotary motion valve, that is ball valve, butterfly valve using rack and pinion, scotch yoke or complex type actuator, which its stem rotates 90 degrees. Before installation, be sure to check for following installation components.

- ① YT-2500/2550R main body
- ② Fork lever and lever spring
- ③ 1 set of bracket
- ④ 4 pcs of hexagon head bolts (M8 x 1.25P)
- ⑤ 4 pcs of M8 plate washer

YT-2500/2550R Installation Example

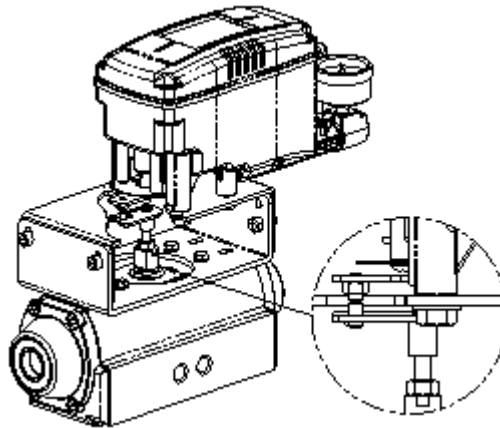

YT-2500/2550R on Fork Lever

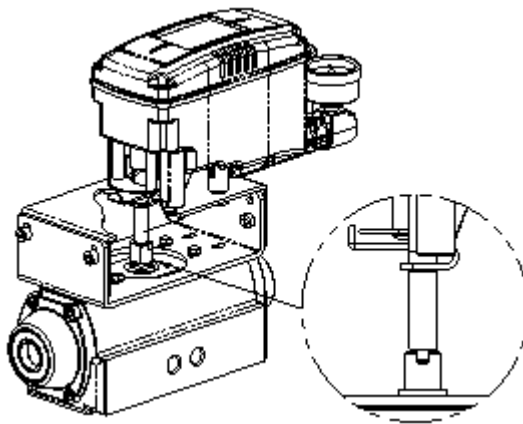

YT-2500/2550R on NAMUR Lever

Bracket Information

YT-2500/2550R is supplied with standard bracket. The bracket can be used for Fork lever and NAMUR bracket. Please see <Figure 9, 10, & 11> for more detailed information.

Actuator stem height (H)	Markings of bolt holes			
	A-L	B-L	A-R	B-R
20mm	H : 20	H : 20, 30	H : 20	H : 20, 30
30mm	H : 30	H : 20, 30	H : 30	H : 20, 30
50mm	H : 50	H : 50	H : 50	H : 50

<Figure 9>

- 1) Standard actuator stem height (H) is 20, 30, or 50 mm. After checking "H", assemble with the bracket as shown in <Figure 9, 10, 11>

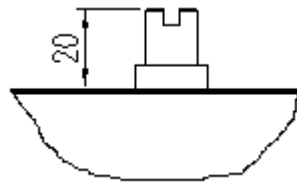

Actuator Stem (H)

Actuator

<Figure 10>

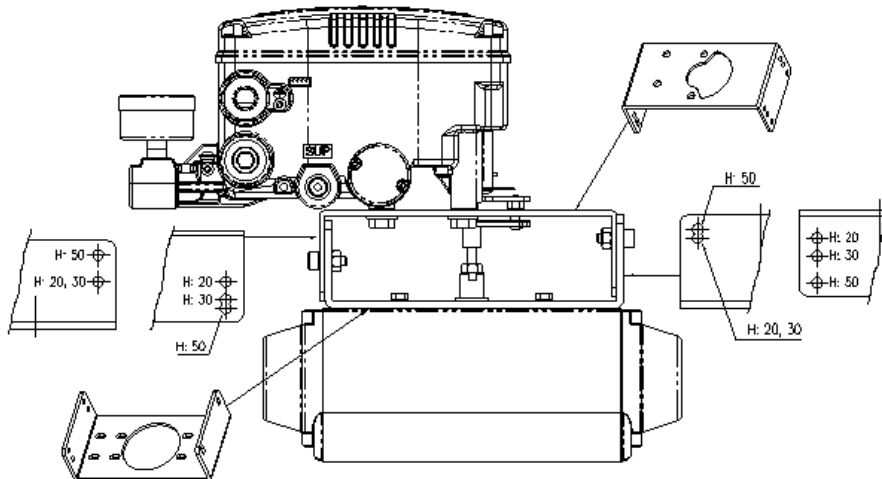

<Figure 11>

* For example, when "H" is 30mm, A-L should be locked with H:30 hole and B-L in H:20,30, A-R with H:30 and B-R with H:20,30 marking.

- 2) Attach bracketed YT-2500/2550R to the actuator by using hexagon-headed and wrench bolts. Size of the bracket hole is 6mm. When tightening bolts, please use spring washer or similar for firm attachment to the actuator, so YT-2500/2550R will not be affected by vibration or any other impact. The direction of bracket is different by operating condition, but normally, the positioner is installed as shown in <Figure 12.>

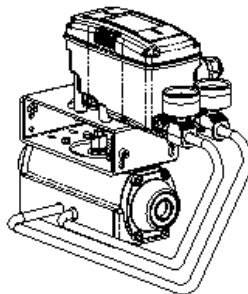

Direction A

<Figure 12>

- 3) Set rotation position of the actuator stem at zero point, "0%". For a single type of actuator, it is easy to check zero point, because the actuator stem is positioned at zero point when there is no supply pressure. If double acting actuator is used, check actuator stem's rotation direction (clockwise or counter-clockwise) by supplying pressure.
- 4) Install the fork lever as shown in <Figure 13> after setting actuator stem at zero point. Check the direction of the actuator stem – clockwise or counter-clockwise. Installation angle of the fork lever should be 45 degrees based on the linear shaft. For NAMUR shaft, the angle does not matter.

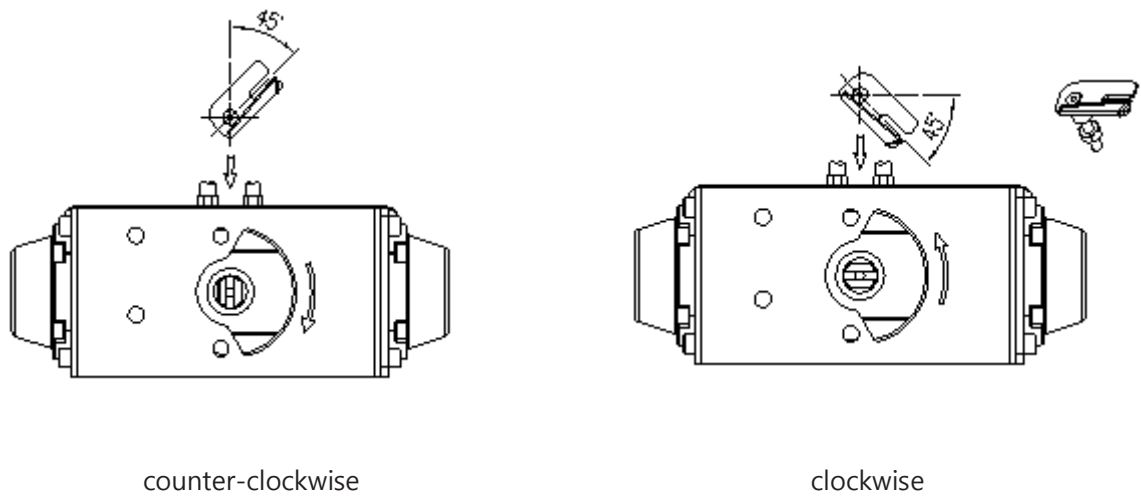

<Figure 13>

- 5) After setting fork lever position, assemble lock nuts which are located on the bottom of the fork lever. Make sure to set the height of upper fork lever between 6-11 mm, which is lower than upper bracket height. <Figure 14>

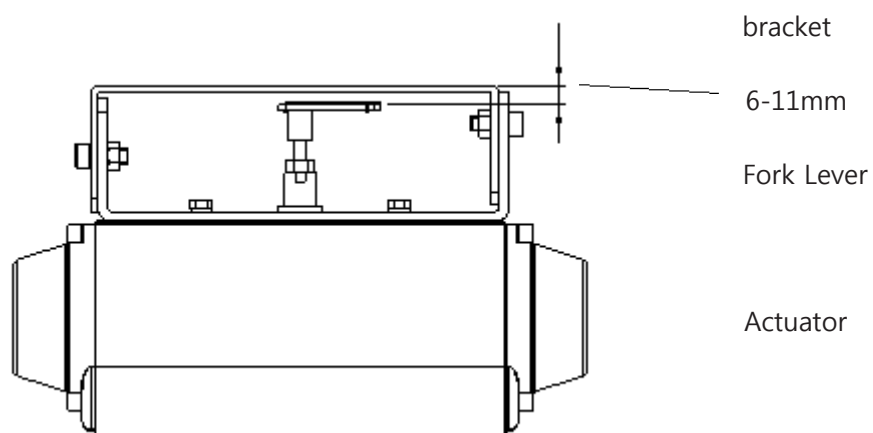

<Figure 14>

-
- 6) Attach YT-2500/2550R to the bracket. Fix the clamping pin on the main shaft's center of YT-2500/2550R and insert connection bar into the fork lever slot, so it can be locked to the fork lever spring. This sets the alignment of the main shaft of YT-2500/2550R and center of the actuator stem. Bad alignment of the main shaft and the actuator stem lowers YT-2500/2550R's durability, because too much force will be on the main shaft of YT-2500/2550R. <Figure 15>

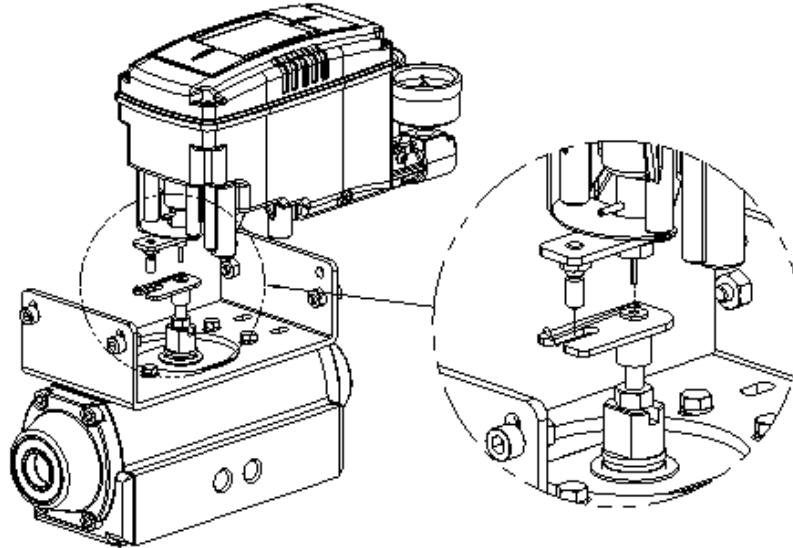

<Figure 15>

- 7) Tighten YT-2500/2550R base and the bracket with hexagon-headed bolts and plate washer. It is recommended to tighten four bolts after checking YT-2500/2550R's position. <Figure 16>

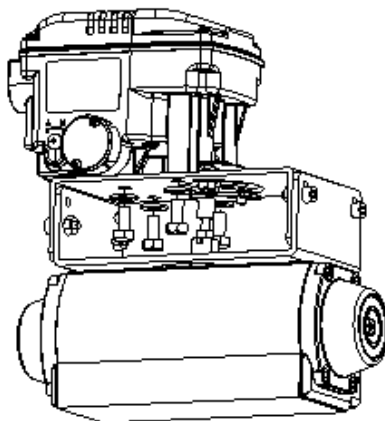

<Figure 16>

Connection

Connection - Piping

Note

- To avoid entering moisture, oil, or dust into the product, please carefully make selection of supply pressure compressor.
- It is recommended to attach air filter regulator before supply port of YT-2500/2550R.

Supply Pressure Condition

- ① Dry air with at least 10°C lower than ambient temperature.
- ② Avoid from dusty air. Filter can only sort 5 micron or larger.
- ③ Avoid any oil.
- ④ Comply with ANSI/ISA-57.3 1975(R1981) or ISA S7.3-1975(R1981).
- ⑤ Not to be used beyond the range of 1.4 - 7 kgf/cm² (140 - 700 kPA).
- ⑥ Set air filter regulator's supplied pressure 10% higher than actuator's spring range pressure.

Pipe Connection

- ① Make sure inside of pipe is emptied.
- ② Do not use pipeline that is squeezed or has hole.
- ③ To maintain flow rate, use the pipeline that has more than 6mm inner diameter. (10mm outer diameter)
- ④ Do not use extremely long pipeline system. It may affect flow rate due to the friction inside of the pipeline.

Piping Connection with Actuator

Single acting actuator

YT-2500/2550 series single acting type is set to use OUT1 port. OUT1 port should be connected with supply pressure port from actuator when using single acting type of spring return actuator. <Figure 17 & 18>

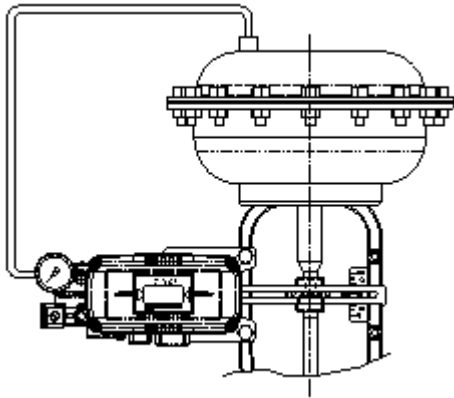

<Figure 17: YT-2500/2550L>

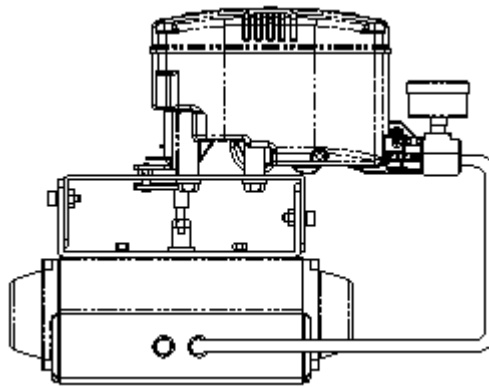

<Figure 18: YT-2500/2550R>

Double acting actuator

For YT-2500/2550 series double acting type, when inputting current signal, supply pressure is out from OUT1. Please refer to <Figure 19 & 20>

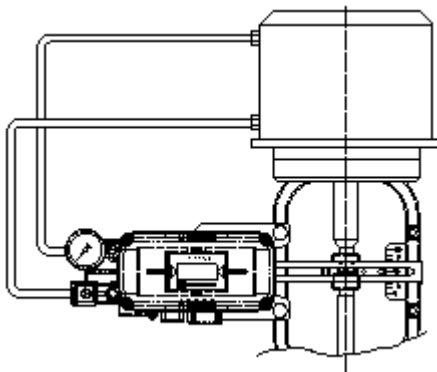

<Figure 19: YT-2500/2550L>

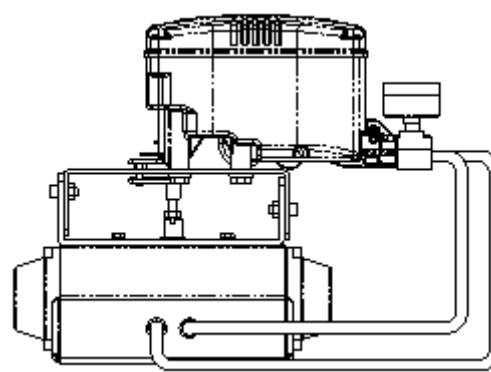

<Figure 20: YT-2500/2550R>

Connection - Power

Note

- Before connecting terminal, please make sure that power is off completely.
- Use ring type terminal to protect against oscillation or other impacts.
- YT-2500/2550 series (except internal PTM type) must use DC 4-20mA. Minimum supply current should be 3.2mA for standard YT-2500/2550, and minimum 3.8mA should be supplied for YT-2500/2550 with HART communication. The power should not exceed 24mA.
- YT-2500/2550 series with PTM option, separate power should be supplied to PTM. The voltage should be between 9~27V and not exceeding 30V.
- YT-2500/2550 must be grounded.

- Please use twisted cable with conductor section area 1.25 mm² and that is suitable for 600V (complying to the conductor table of NEC Article 310.) The outer diameter of the cable should be between 6.35~10mm. Use shield wire to protect against electro-magnetic field and noise.
- Please do not install the cable near the equipments such as high-capacity transformer or motor which creates noise.

Terminal box 1

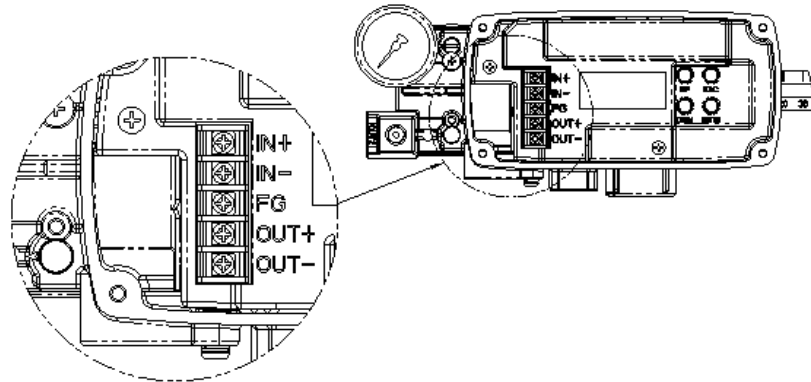

IN +	Input Signal (+)
IN -	Input Signal (-)
FG	Ground
OUT +	Feedback Output (+)
OUT -	Feedback Output (-)

<Figure 21: Terminal box for standard YT-2500/2550>

Terminal box 2

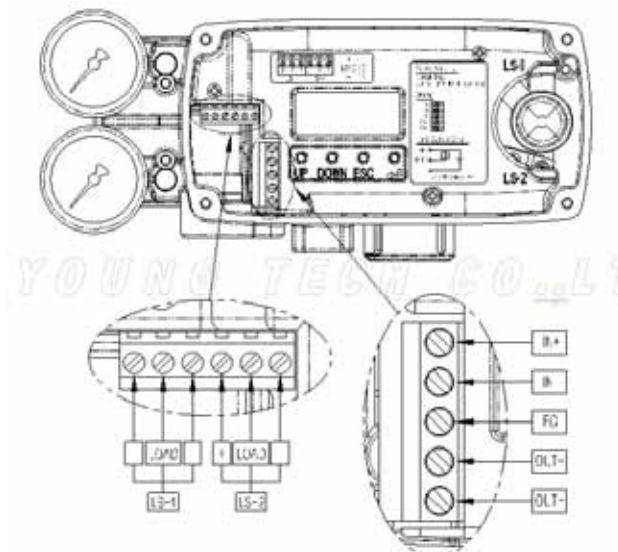

<Figure 22: Terminal box for YT-2500/2550 + L/S Mechanical>

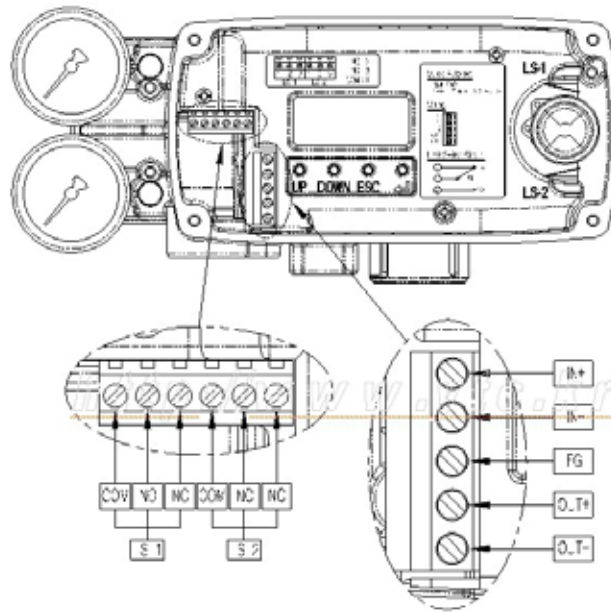

<Figure 23: Terminal box for YT-2500/2550 + L/S Proximity>

Connection - Feedback Signal

- 1) Open product cover by opening 4 M4 bolts.
- 2) Loose terminal locking bolts of feedback signal for position transmitter on terminal plate.
- 3) Insert cables through cable connector in YT-2500/2550.
- 4) Use ring type when connecting terminals in order to lock completely.
- 5) Insert terminal bolts through the holes and lock them with (+) and (-) terminals on the terminal plate. Tighten bolts with 1.5Nm (15 kgf/cm) torque.
- 6) Be sure the polarities of the terminals are properly connected.

Connection - Ground

- 1) Ground must be done before operating YT-2500/2550.
- 2) Inside of the terminal box, locate ground terminal plate at the center of the terminal plate.
<Figure 24> Use any type of ground terminal with the resistance less than 100hm.
- 3) Make sure to use ring type ground cable in order to lock them completely.

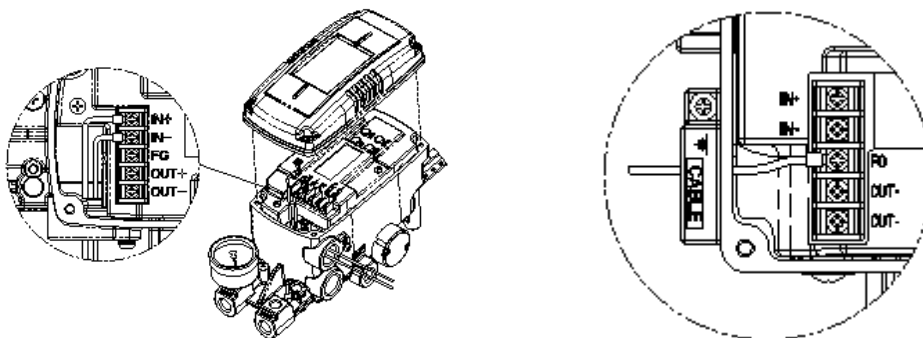

<Figure 24: Ground Terminal>

Adjustment

Adjustment - Variable Orifice

Hunting can be occurred when the actuator's volume is too small. In order to prevent hunting, orifice can be adjusted. By adjusting orifice, the flow rate of supply pressure to actuator can be adjusted. To adjust, use (-) driver to control the orifice. <Figure 25>

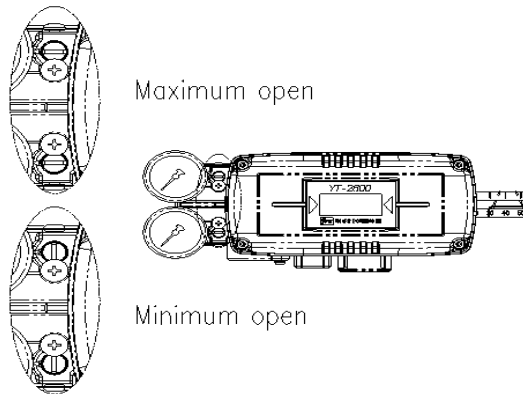

<Figure 25: Variable Orifice Adjustment>

Adjustment - Option Modules PCB (PTM/HART)

Position Transmitter (PTM), HART Communication (HART), or PTM+HART option can be installed on standard YT-2500/2550 series PCB. Please refer to <Figure 26> for each option's PCB.

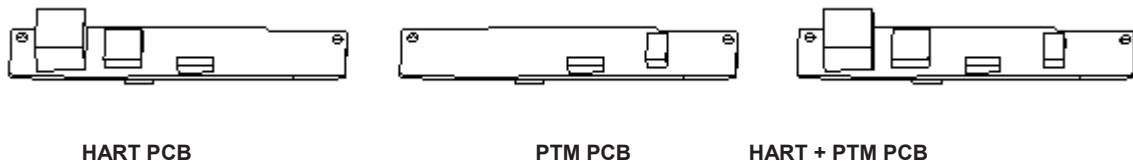

<Figure 26: PCB for Each Options>

Please install the PCB modules as follows.

- 1) Open the cover and separate main PCB board from the body.
- 2) By referring to <Figure 27>, lock 2 bolts on the bottom with PCB supports.
- 3) Insert 14-pins exactly and completely.
- 4) Re-install main PCB on the main body.

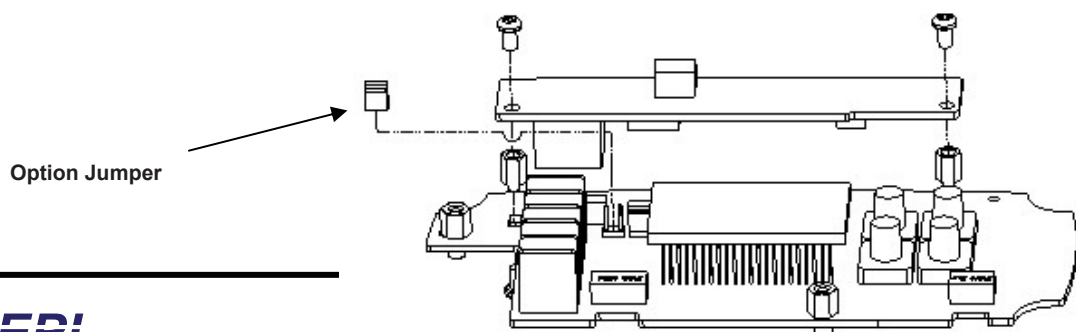

<Figure 27>

* When HART option PCB installed on the main PCB, please make sure to REMOVE option jumper
<Figure 27> After installing PTM option board, please adjust TR_ZERO and TR_END from
HAND CAL mode in order to get accurate output values.

Limit Switch Adjustment

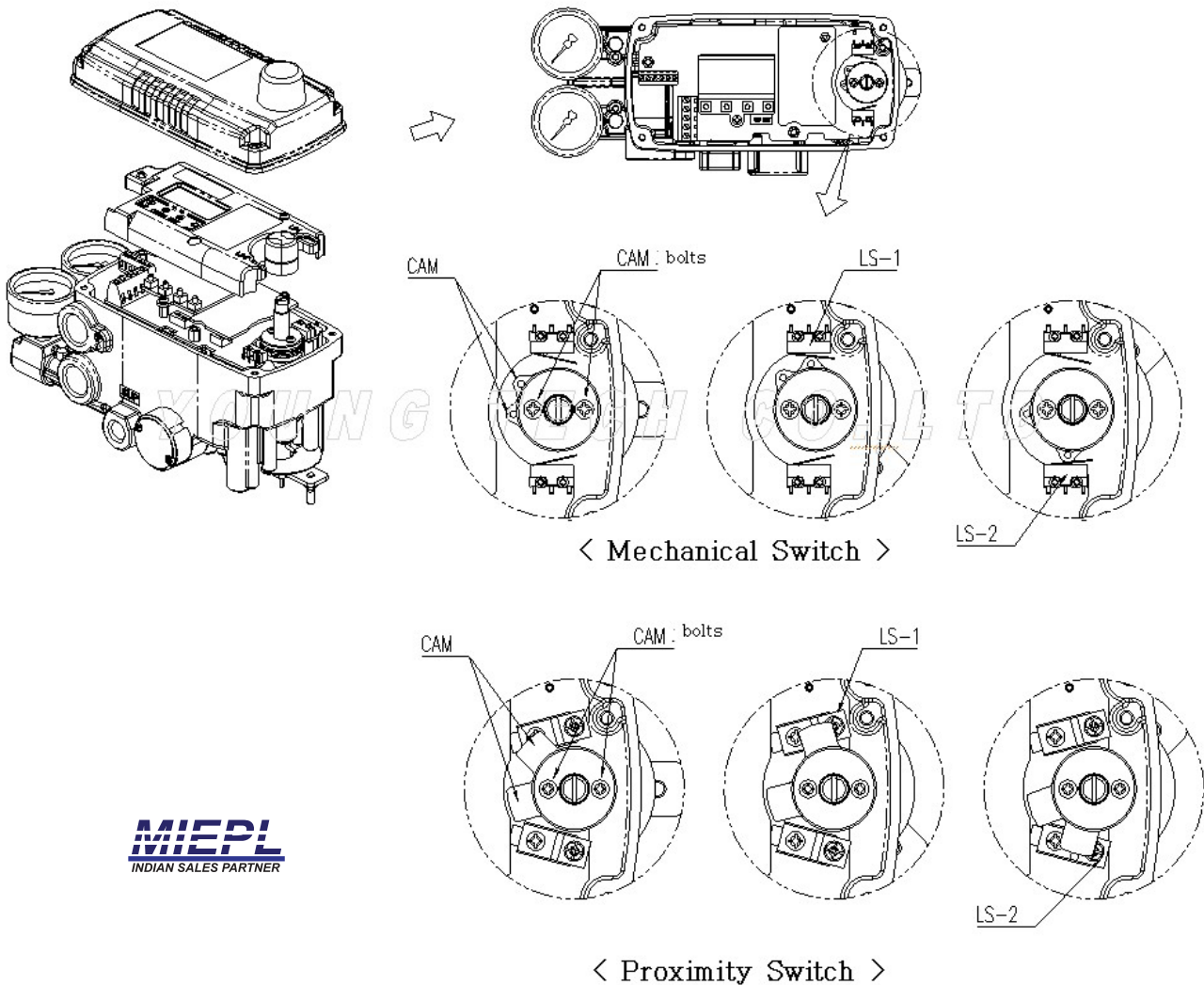

Auto Calibration and Basic Operation

Note

Following process will operate valve and actuator. Before starting Auto Calibration, please separate valve from the entire system, so Auto Calibration will not affect entire valve process.

Button Description

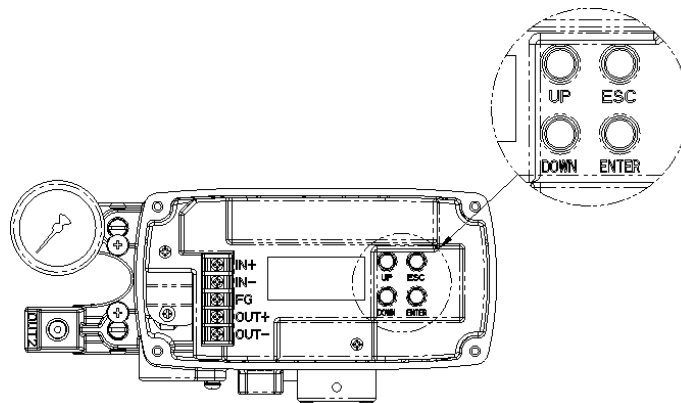

YT-2500/2550 series has 4 buttons and enable to perform various functions. Please refer to the below table for further description..

Button	Function
<ENTER>	Enter to main menu and sub-menus, save adjusted parameter values, etc.
<ESC>	Return to previous menu.
<UP> & <DOWN>	Move to next menu, change parameter values, etc.

Run Mode (RUN)

After power connection to YT-2500/2550 series, following message will appear on LCD screen within 6 seconds. <Figure 28>

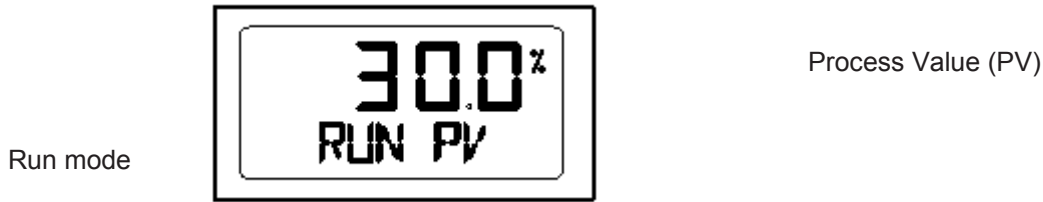

<Figure 28: LCD Message>

"RUN" indicates that YT-2500/2550 adjusts valve stroke with receiving signals (4~20mA) and "PV" indicates the process value. In RUN mode, the valve stroke continuously changes according to the input signal. There are six types of display message in RUN mode. <Figure 29>

①	Run PV	Process Value	Valve Stroke (%)
②	Run SV %	Set Value	Input Signal (0~100%)
③	Run SV mA	Set Value	Input Signal (4~20mA)
④	Run MV	Manipulate Value	Motor/Piezo Valve Manipulate Value (Digit)
⑤	Run Vel	Velocity	Current Valve Stem's Velocity (Digit)
⑥	Run Err	Error	Difference between SV and PV (%)

<Figure 29: Type of display message>

To change display, push <ESC> and <UP> at same time. The display will change in order indicated above. If <ESC> and <DOWN> pushed simultaneously, the order will be displayed in opposite order. By pressing <ESC>, the display will return to RUN Mode.

Auto Calibration (AUTO CAL)

Auto Calibration (Auto Cal) automatically calibrates YT-2500/2550 in very simple manner. Auto Cal process takes about 2~3 minutes, and the duration of the process varies upon the size of the actuator as well. There are 3 types of Auto Cal. <Figure 30>

	Zero Point	End Point	KP KI KD	RA / DA
AUTO1	○	○	×	×
AUTO2	○	○	○	○
AUTO3	×	×	○	○

<Figure 31>

<Figure 30>

* It is recommended to calibrate the positioner under AUTO2 when setting the system initially.

Auto 1 Calibration

Auto 1 Calibration is mainly for the parameter which needs to be calibrated in order for valve system to operate, will be calibrated; however, KP, KI, and KD values do not change.

- ① After connecting power, "READY 6,5,4,3,2,1" message will be appeared on LCD screen.
- ② Push <ENTER> button for 6 seconds at RUN mode and AUTO CAL message will be appeared.
- ③ Push <ENTER> and AUTO1 mode will be displayed.
- ④ Push <ENTER> and AUTO1 will be started.
- ⑤ After several minute, COMPLETE message will be appeared to indicate that AUTO1 calibration has been completed.



<Figure 31: AUTO1 Calibration>

Auto 2 Calibration

Auto 2 Calibration sets all of the parameter which needs to be calibrated in order for valve system to operate. Auto 2 Calibration is recommended when YT-2500/2550 is first installed on the valve system. <Figure 32>

- ① After connecting power, "READY 6,5,4,3,2,1" message will be appeared on LCD screen.
- ② Push <ENTER> button for 6 seconds at RUN mode and AUTO CAL message will be appeared.
- ③ Push <ENTER> and AUTO1 mode will be displayed.
- ④ Push <DOWN> and AUTO2 mode will be displayed.
- ⑤ Push <ENTER> and AUTO2 will be started.
- ⑥ After several minute, COMPLETE message will be appeared to indicate that AUTO2 calibration has been completed.





<Figure 32: AUTO2 Calibration>

Auto HF Calibration

Auto HF Calibration sets all of the parameters, like Auto 2; however, it is used for high friction valve environment

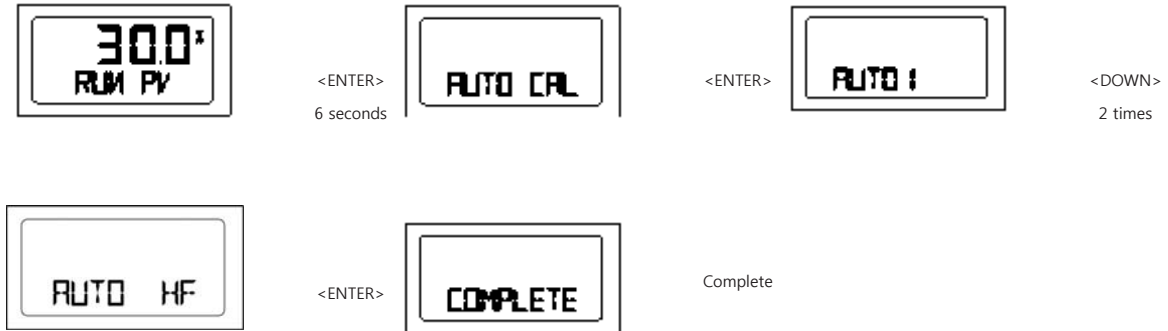

<Figure 33: AUTO HF Calibration>

Manual Mode (MANUAL)

MANUAL MODE is used to move valve stem manually. During MANUAL MODE, YT-2500/2550 moves valve strokes, not by input signal. The movement of the stroke does not affect YT-2500/2550 saved data values, and it just moves valve strokes up/down physically. <Figure 34>

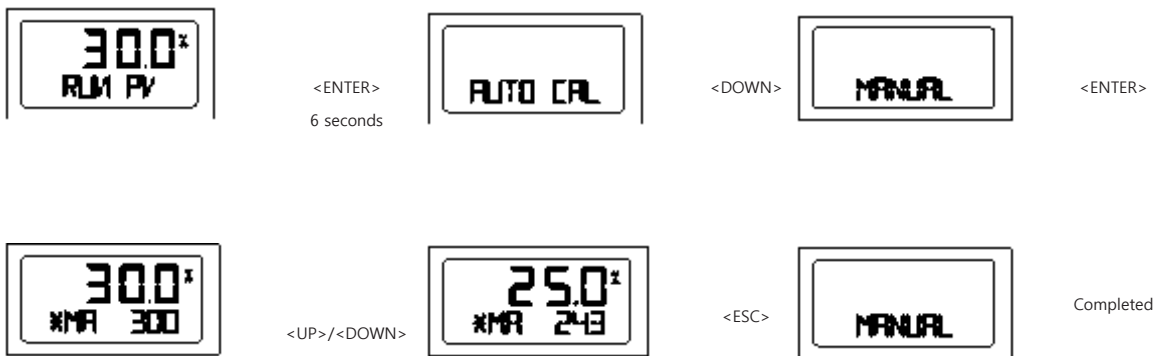

<Figure 34: MANUAL MODE>

Tip when increasing/decreasing value

<UP> only	Increase stem value slowly
<UP> + <ENTER>	Increase stem value quickly
<DOWN> only	Decrease stem value slowly

<DOWN> + <ENTER>	Decrease stem value quickly
------------------	-----------------------------

Parameter Mode (PARAM)

AUTO CAL optimizes most of the valve actuator controls. However, in some instances, there can be exceptions. Usually hunting or oscillation occurs when the valve actuator controls did not optimize. When this occurs, hunting or oscillation can be prevented by adjusting parameter values and DeadZone.

4 Types of Parameter and Adjustment

- ① Dead-Zone (dEAdZONE)
- ② P-value (KP)
- ③ D-value (Kd)

Note

When parameter values are changed, the positioner shows the status of the changes in real-time. In another words, you do not need to return to the RUN mode to observe the adjustments. However, in order to save the change, <ENTER> button must be pressed.

Dead-Zone (dEAdZONE)

Dead-Zone indicates the percentage of error allowance. When there is high packing friction level, hunting or oscillation can be occurred. In this case, by adjusting Dead-Zone, hunting or oscillation can be prevented. <Figure 35>

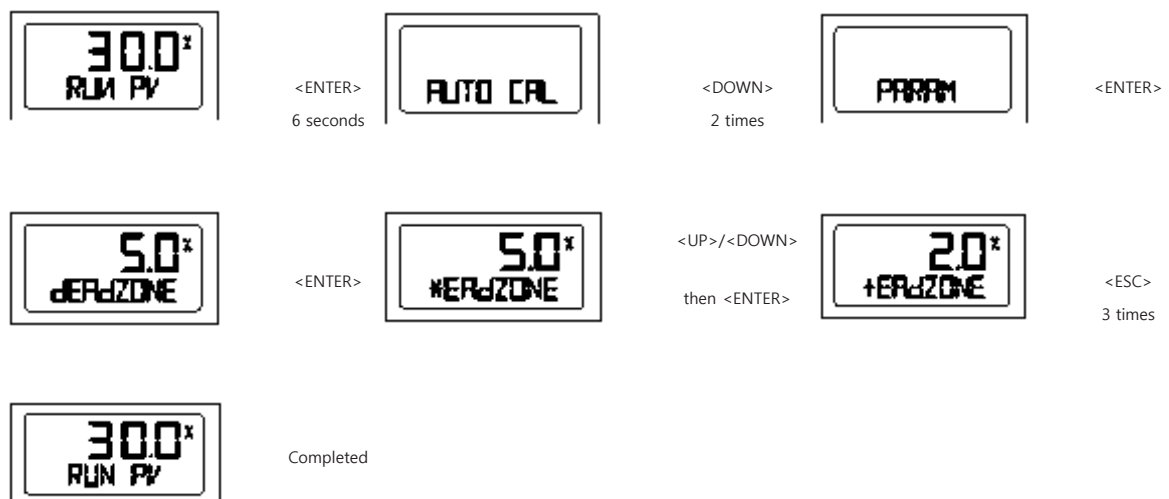

<Figure 35: Adjusting Dead-Zone>

P-Value (KP1)

P-value indicates the ratio of the compensation signal based on the percentage of error allowance. As KP1 increases, the positioner finds the target value quickly, but it is more likely to occur hunting. On the other hand, as KP decreases, the positioner finds the target value rather slowly, but it is less likely to occur hunting. <Figure 36>

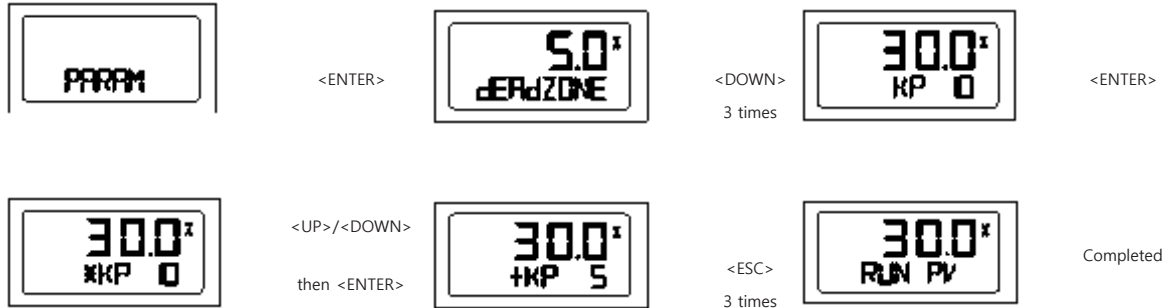

<Figure 36: Adjusting P-Value>

P2-Value (KP2)

KP2 is similar to KP1. However, unlike KP1, KP2 indicates the P-value when the valve stem move upward for the reverse action, and for the downward movement for the direct action actuator.

D1-Value (Kd1)

Kd1 is differential value of which will be added on to the compensation signal based on the percentage of error allowance.

D2-Value (Kd2)

Kd2 is similar to Kd1. However, unlike Kd1, Kd2 indicates the D-value when the valve stem moves upward for the reverse action, and for the downward movement for the direct action actuator.

PT-Value (PT1)

PT1 value indicates the minimum time interval <msec> of the valve control signal to operate. If the value is too large, then oscillation may occur. On the other hand where the value is too low, then the response time of the positioner can become very slow.





PT-Value (PT2)

PT2 is similar to PT1. However, unlike PT1, PT2 indicates the PT-value when the valve stem moves upward for the reverse action, and for the downward movement for the direct action actuator.

KP_ and D_ Value

The concept of KP_ and D_ values are similar to the P and D value. However, KP_ and D_ value affected when the target stroke value is about to be reached within +/- 1% of valve stroke deviation.

Hand Calibration Mode (HAND CAL)

When user wants to confirm the calibration of the positioner after AUTO Calibration has been completed, user can manually calibrate the positioner as well by entering into Hand Calibration Mode.

Zero-Point (PZ_ZERO) and End-Point (PZ_END) for Valves

In PZ_ZERO mode, the zero point of valve can be adjusted, and in PV_END mode, the end point of the valve can be adjusted. <Figure 37>

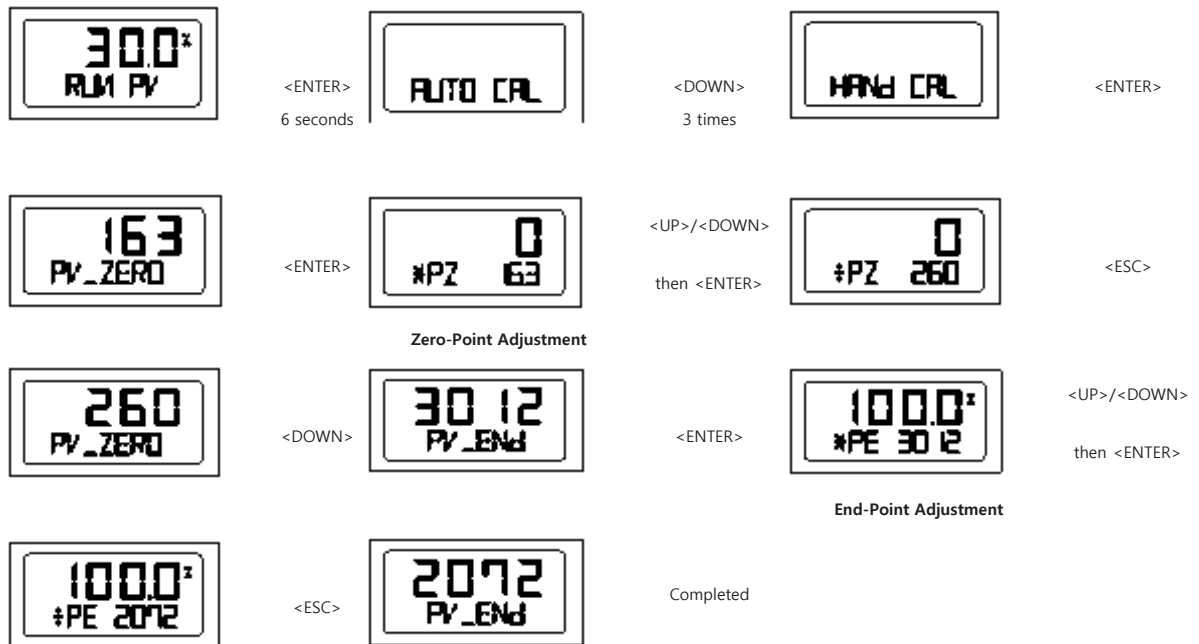

<Figure 37: PZ_ZERO and PZ_END Adjustment>

Zero-Point (TR_ZERO) and End-Point (TR_END) for Transmitter

In TR_ZERO mode, the zero point of transmitter can be adjusted, and in TR_END mode, the end point of the transmitter can be adjusted. These points should be adjusted when output signal is not constant, and/or the user wants to set transmitter output signal and actual stroke not equally. The connection should be done as shown in <Figure 38> and the procedure can be done as shown in <Figure 39>

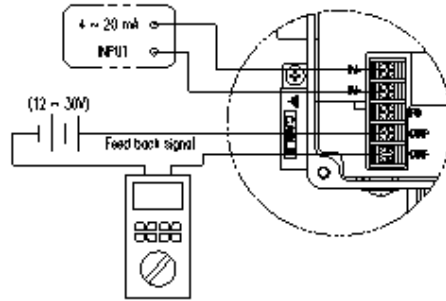

<Figure 38: Connection>

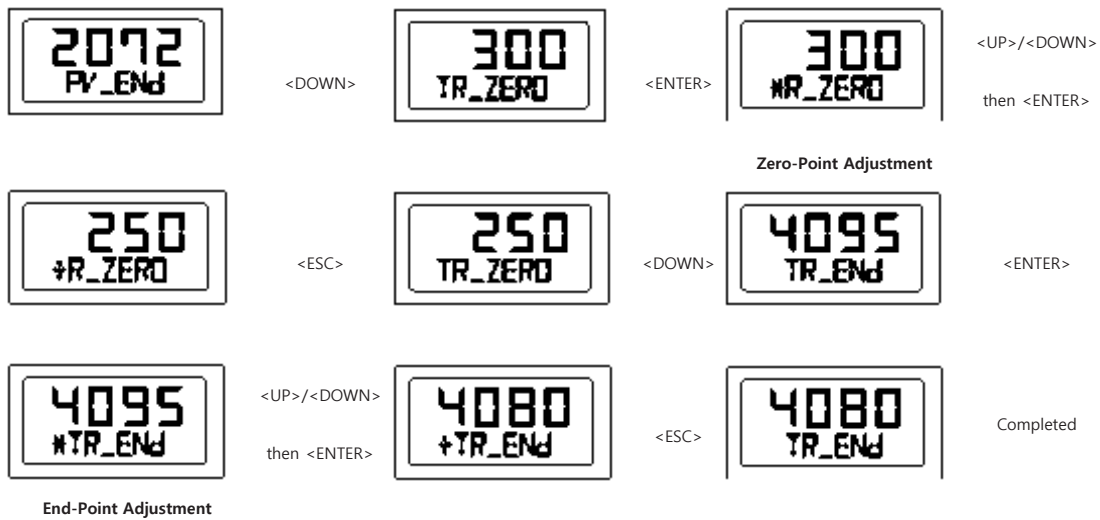

<Figure 39: TR_ZERO and TR_END Adjustment>

End-Point Ratio for Valve (PE TRIM)

When reverse acting <RA> actuator is used, End-Point can be adjusted within 10% of total stroke, without adjusting valve's Zero-Point. <Figure 40>





<Figure 40: PE_TRIM Adjustment>

Normal/Reverse Feedback Signal (TR NORM/REV)

The feedback signal from position transmitter can be viewed as normal or as reverse. For example, actual input signal of 4mA can be viewed as output signal of 20mA. <Figure 41>



<Figure 41: TR_NORM/REV>

Valve Mode (VALVE)

Acting Adjustment (ACT)

The positioner can be set as D/A (Direct Action) or R/A (Reverse Action.) <Figure 42>

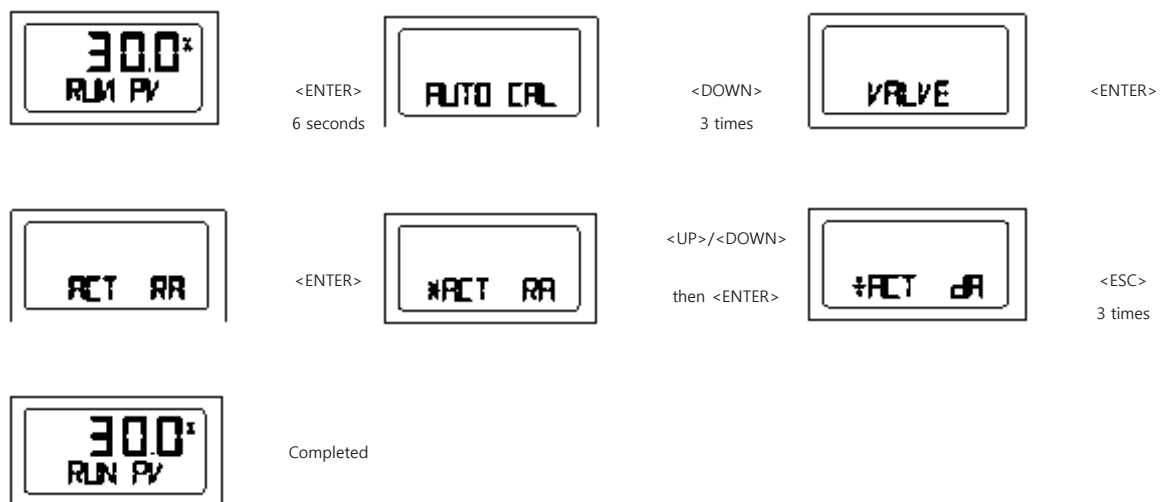

<Figure 42: D/A or R/A Adjustment>

Characteristics Adjustment (CHAR)

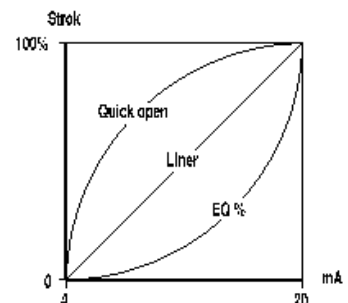

The positioner's characteristics can be set depends on user's preference. <Figure 43> There are 3 types of characteristics - Linear (LIN), Equal Percentage (EQ), and Quick Open (QO). Following diagram, <Figure 44>, graphically shows each characteristics.

<Figure 43>

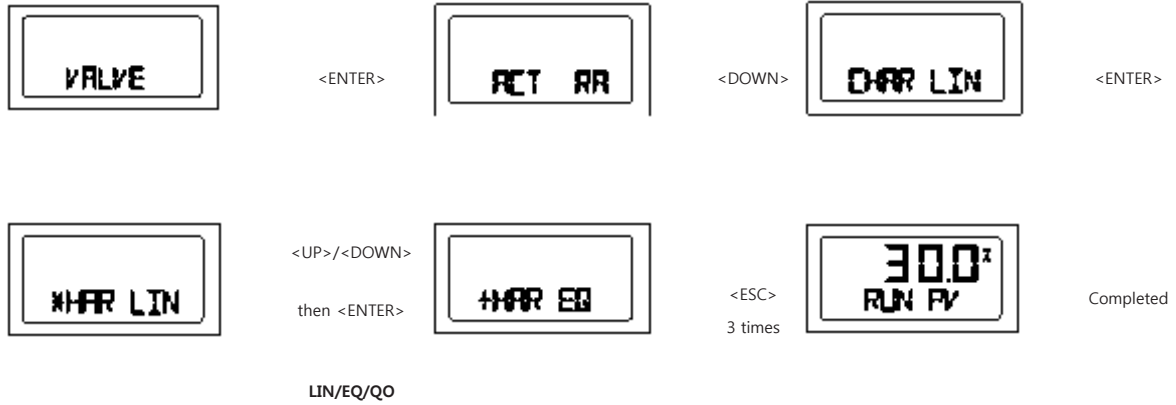

<Figure 44: Characteristics Adjustment>

User Characteristics (USER SET)

When user has a specific characteristic which is not included in above section, the characteristic curve can be made by selecting 16 points of the curve. <Figure 45>

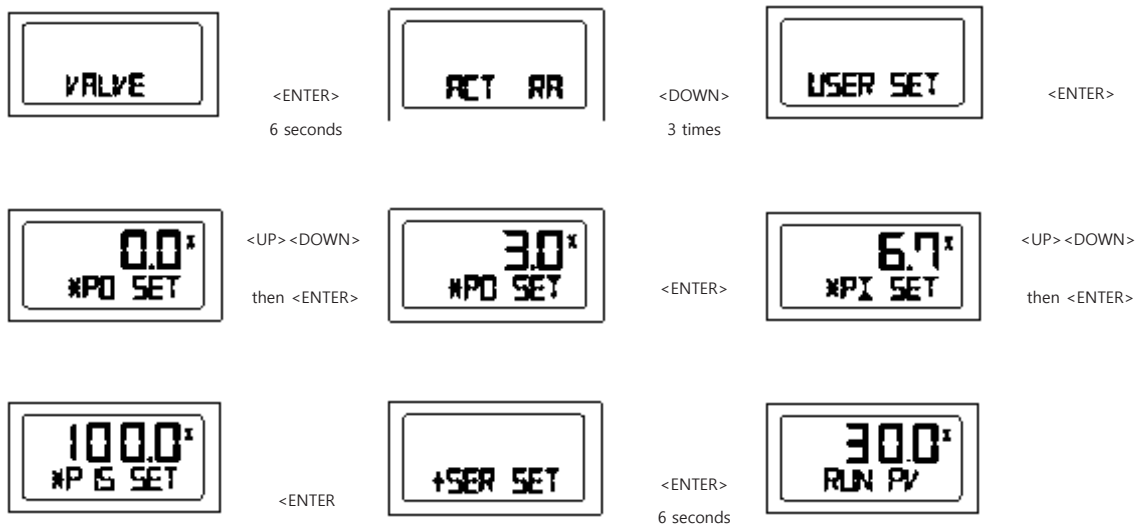

<Figure 45: USER SET Adjustment>

Tight Shut Open (TSHUT OP)





TSHUT OP allows the valve to open completely when the input signal reaches around 20mA. <Figure 46>

<Figure 46: TSHUT OP Adjustment>

Tight Shut Close (TSHUT CL)

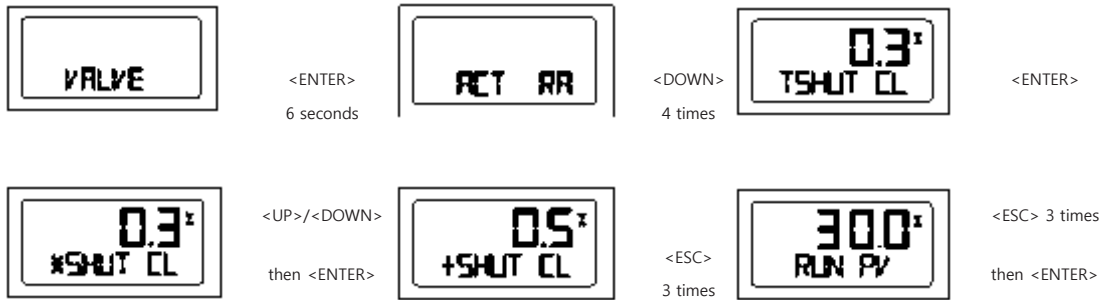

TSHUT CL allows the valve to close completely when the input signal reaches around 4mA. <Figure 47>

<Figure 47: TSHUT CL Adjustment>

Split Range Control (SPLIT)

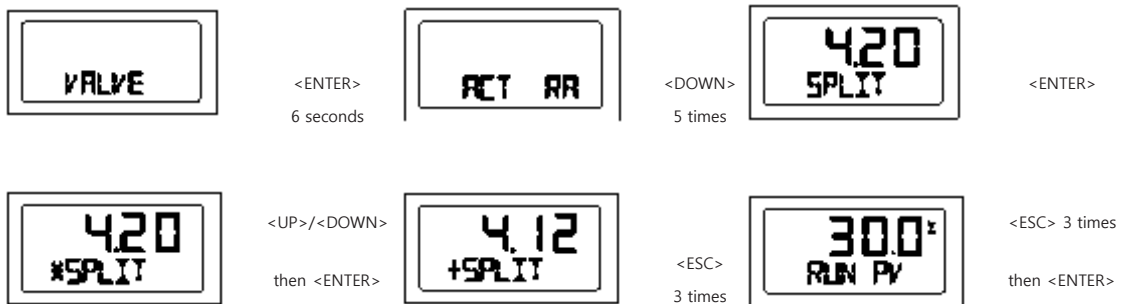

The valve can be controlled by three input signal - 4~20mA, 4~12mA, or 12~20mA. <Figure 48>

<Figure 48: SPLIT Adjustment>

View Mode (VIEW)

In this mode, user can set the positioner to display different information such as stroke value in percentage (%) or in values. <Figure 49>

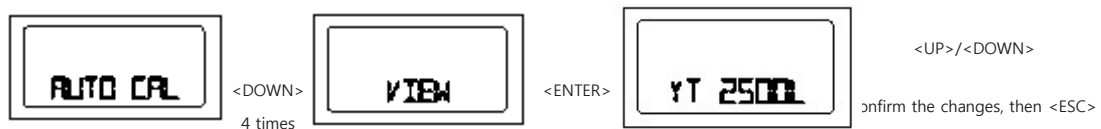



	Description
YT-2500L	Positioner model
VERSION	Main software version
HART V	HART Protocol version
POL Addr	Channel address that is used in HART Protocol
BIAS VI	BIAS value for motor/piezo valve control. Can be adjusted only by manufacturer.
0Y 0d	Total used time duration. If a unit was used less than 1 minute, the time does not accumulate.
FULL_OP	Time elapsed for valve to fully open
FULL_CL	Time elapsed for valve to fully close
VM NOR	Display type of valve stroke on LCD. (either in percentage or value)
Erro	Display error code or warning message. <Figure 53>
VALUE I	Current I-Value. Can be adjusted only by manufacturer.
ABS	Display absolute resistance value.

<Figure 49: VIEW Adjustment and Description Table>

Error and Warning Code

YT-2500/2550 series provides error and warning codes if there is/are problem/s.

Error Code

Error code will be displayed when the positioner cannot be operated.

Error Code	Code Description and Cause	Action
MT ERR L	Positioner is improperly installed. Positioner lever is not parallel to the ground at 50% point. Lever is at lower position than actual 50% point.	Re-install/mount the positioner. Make sure the feedback lever does not touch the stopper at both 0% and 100%.
MT ERR H	Positioner is improperly installed. Positioner lever is not parallel to the ground at 50% point. Lever is at higher position than actual 50% point.	Re-install/mount the positioner. Make sure the feedback lever does not touch the stopper at both 0% and 100%.
CHK AIR	Valve does not operate when positioner receives "Full Open" signal during Auto Calibration.	Check if supply pressure is stable and appropriate.
RNG ERR	Operating angle is too small due to improper mounting of positioner.	Adjust bracket so the positioner can be mounted closer to actuator.
C	Error 10% or above persists more than 1 minute. No valve movement. Friction of valve is too large.	Perform BIAS Calibration. Check setting pressure of actuator and set the pressure as recommended.

	Setting pressure of actuator changes.	
D	I-Value reaches at maximum or minimum limit point. Friction of valve changes. Setting pressure of actuator changes.	Perform AUTO Calibration. Check setting pressure of actuator and set the pressure as recommended.

Warning Code

Warning Code	Code Description and Cause	Action
B	Pv End - Pv Zero range is below 500. The angle of feedback lever is too small.	Re-install/mount the positioner. Make sure the feedback lever does not touch the stopper at both 0% and 100%. After re-installation, perform AUTO1 Calibration.
F	Time elapsed for either Full Open or Full Close is less than 1 second. The size of actuator is too small.	Use variable orifice. Replace actuator with larger capacity.
G	Pv Zero is below 100. The angle of feedback lever is too large.	Re-install/mount the positioner. After re-installation, perform AUTO1 Calibration.
H	Pv End is over 4000. The angle of feedback lever is too large.	Re-install/mount the positioner. After re-installation, perform AUTO1 Calibration.

Warning code will be displayed when the positioner has a possibility of not operating.

Main Software Map

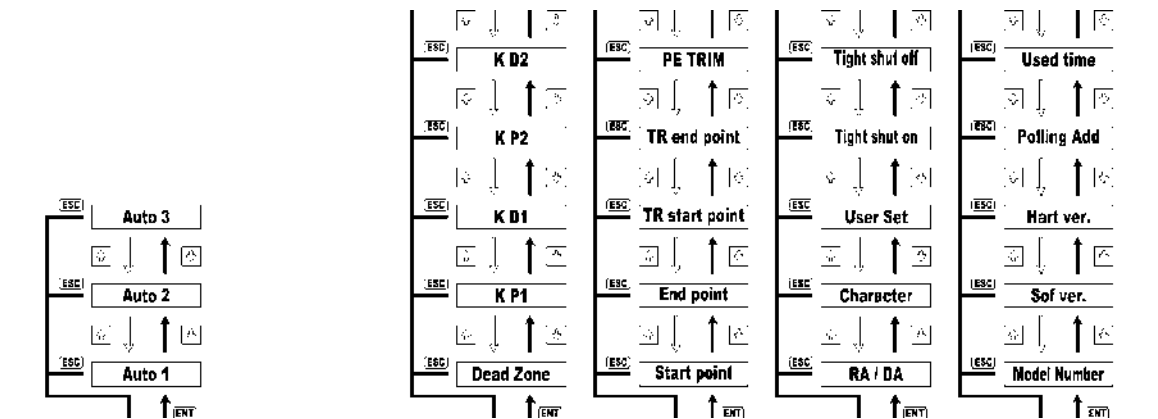

- ↓ : Down button
- ↑ : Up button
- ESC : Esc button
- ENT : Enter button

