

REV. NO.	REVISION DESCRIPTION	DRAWN / DATE	REVIEWED / DATE	APPROVED / DATE
△	DRAWING ARRANGEMENT	HSS/090223	KCH/090223	LYH/090223
△	DRAWING ARRANGEMENT	LJS/110416	KCH/110416	LYH/110416

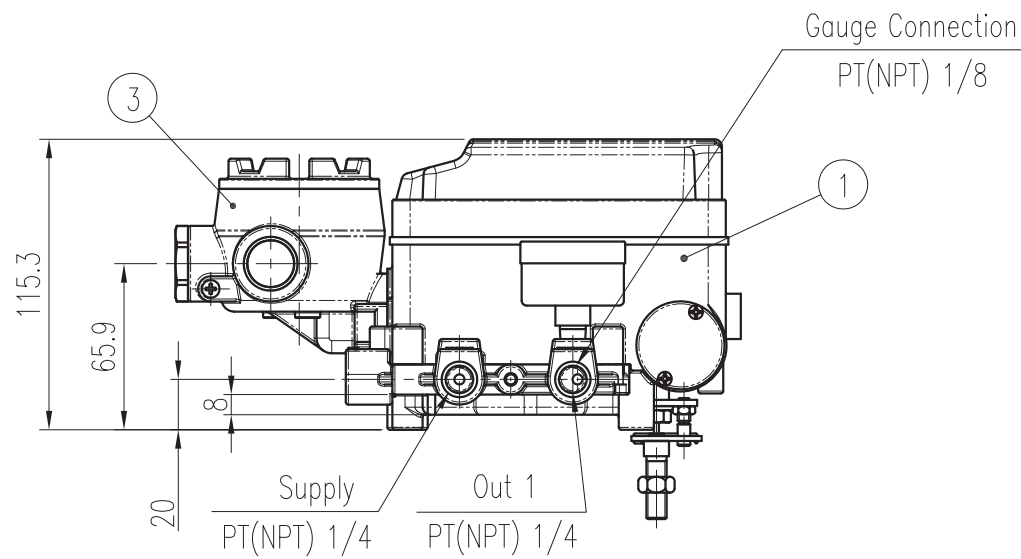

SPECIFICATIONS

Applicable Fluid	Air		Air Connection	PT(NPT) 1/4	
Acting Type	<input type="checkbox"/> Single	<input type="checkbox"/> Double	Gauge Connection	PT(NPT) 1/8	
Input Signal	4 ~ 20 mA DC		Conduit entry	PF 1/2 (G 1/2), NPT 1/2	
Impedance	250±15 Ω		Explosion Proof	<input type="checkbox"/> Ex dm IIB T5	<input type="checkbox"/> Non-Explosion
Supply Pressure	0.14~0.7MPa (1.4~7bar)		Air Consumption	< 3 LPM (Sup.=0.14MPa, 1.4bar)	
Stroke	0° ~ 90°		Flow Capacity	> 80 LPM (Sup.=0.14MPa, 1.4bar)	
Pressure Gauge	<input type="checkbox"/> 0.4MPa	<input type="checkbox"/> 0.8MPa	Protection	IP66	
Linearity	±1.0% F.S.	±2.0% F.S.	Weight	5.7kg (12.6lb)	
Hysteresis	±1.0% F.S.		Actuator Shaft	<input type="checkbox"/> M6	<input type="checkbox"/> L=34
Sensitivity	±0.2% F.S.	±0.5% F.S.		<input type="checkbox"/> M8	<input type="checkbox"/> L=63
Repeatability	±0.5% F.S.		Material	STS316 (Stainless Steel)	
Ambient Temp	Operation	-20°C ~ 70°C (-4 ~ 158°F)			
	Explosion	-20°C ~ 60°C (-4 ~ 140°F)			

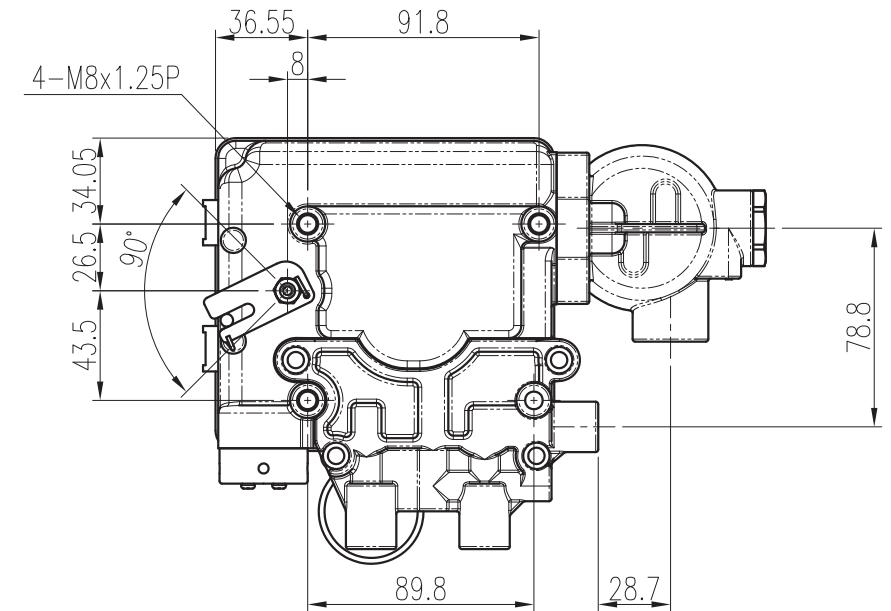
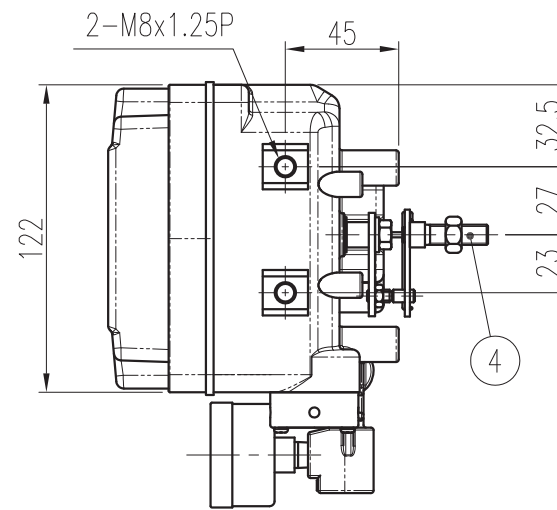
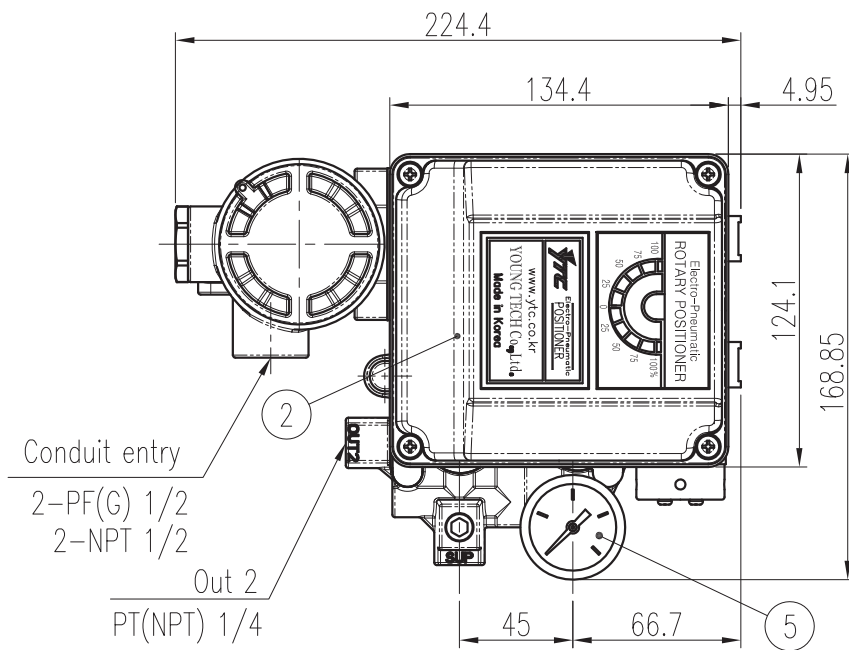
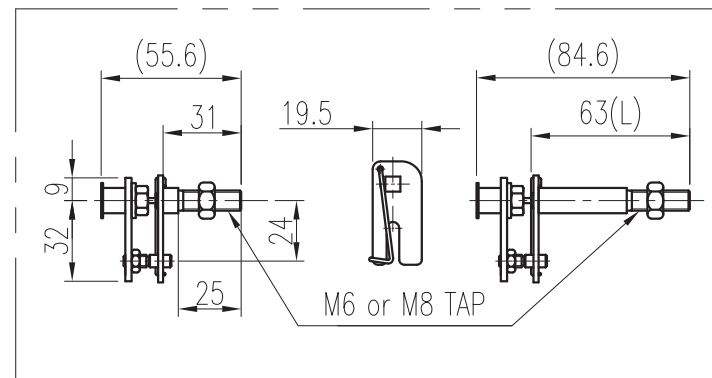

FORK LEVER TYPE

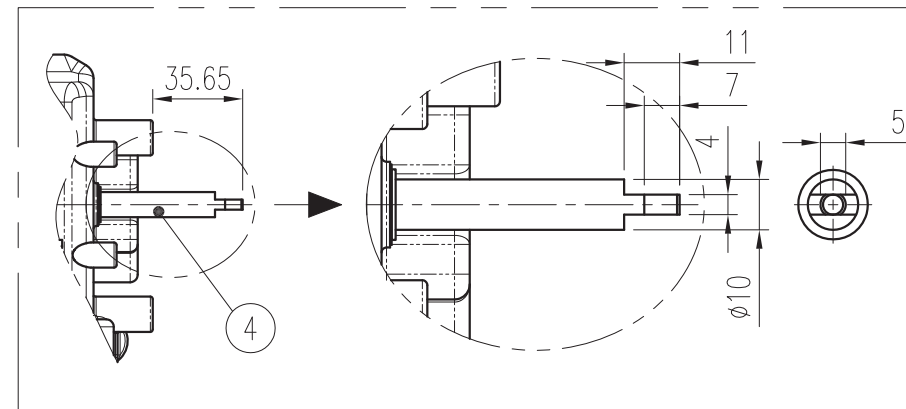

NAMUR SHAFT TYPE

NO.	PART NAME	MATERIAL	Q'TY	REMARK
5	PRESSURE GAUGE	STS304	1	
4	CONNECT LEVER ASS'Y	STS316	1	FORK LEVER, NAMUR
3	JUNCTION BOX	STS316	1	
2	COVER BASE	STS316	1	
1	BODY BASE	STS316	1	

SURFACE TEXTURE		PRODUCT NAME		PROJECT NAME	
		E/P POSITIONER		-	
FINISH TREATMENT		MODEL		YOUNG TECH CO., LTD.	
		YT-1050R		SEOUL, KOREA	
MATERIAL		PROJECTION	SCALE	TITLE	
		3rd	1 / 3	ELECTRO PNEUMATIC LINEAR POSITIONER ASS'Y DWG (STANDARD)	
OTHERWISE NOTE		QUANTITY	SHEET No.	DRAWING NO.	
		1	1 / 1	YT-1050R STANDARD	
GENERAL TOLERANCE				REV.	
				1	